

# CATALOGUE

The image features several blue plastic fasteners and components arranged around the central text. On the left, there is a hexagonal nut with three slots, labeled with the numbers 2, 3, and 5. Below it is a U-shaped anchor bolt. To the right of the text is a large, cylindrical, threaded fastener with a flared base. Above the text is a rectangular component with a slot and a small protrusion.

2018

[www.peygran.com](http://www.peygran.com)



# CONTENTS

01

Company



Pag. 02

02

Floats and  
Trowels



Pag. 07

03

Tile spacers  
and Others



Pag. 13

04

Levelling  
System



Pag. 19

05

Cladding  
Facade  
Anchors



Pag. 33

06

Raised Floor  
Pedestals



Pag. 37

07

Display



Pag. 59

# Company

Peygran represents a group of family companies located in the industrial area of Ibi that develop and produce solutions and technical components for different industrial sectors.

We have more than 30 years experience, firstly focussed as auxiliaries working in the metal and plastic sectors. Currently, we are working with our own range of products offering unique products for professionals. We work with high quality materials and best design in order to provide our customers with effective solutions.

At present, we have more than 6,000 m<sup>2</sup> of useful area in our facilities, distributed between production areas, offices and logistics areas.

## Services under our own brand:

- Development and production of technical solutions and special components.
- Development of new products for our own brand and for third parties.
- Information on technical requirements and technical support as well as training courses on our products for architects, engineers and professionals in general.



# Work with us

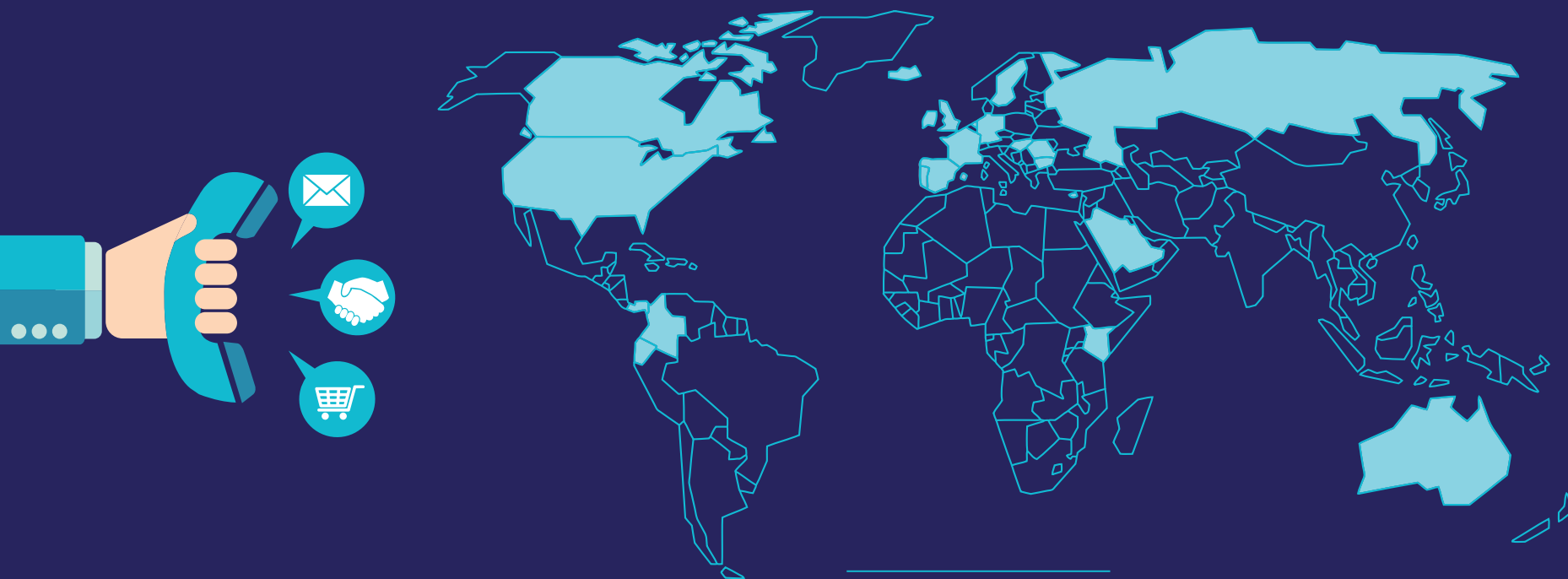

We are seeking new points of sale for expansion, more agents recommending our products and technological partners for the development of innovations and new ideas.

Call +34 966 550 514  
[info@peygran.com](mailto:info@peygran.com)

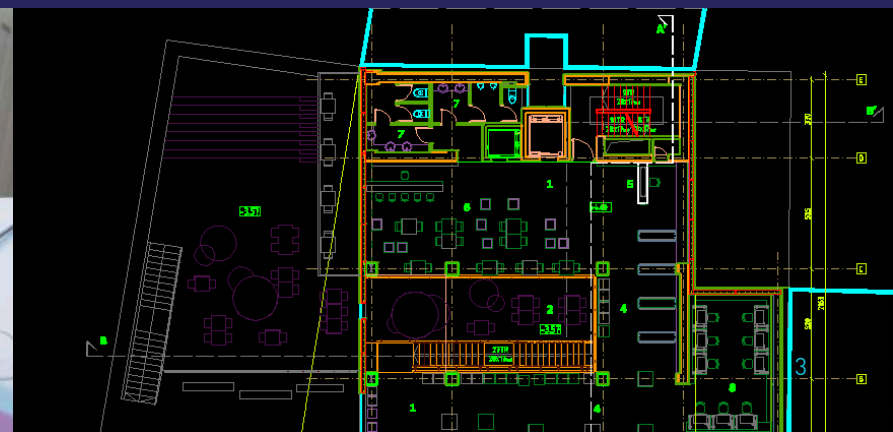

# Web

On our web [www.peygran.com](http://www.peygran.com) you can access our online catalogue and ask for data sheets and additional information on our products and services.

You can also have immediate information on our latest developments.



# Social networks

We are present in social networks.

Follow us on social networks and you will be informed on our latest products, tips, training and instructional videos, promotions, workshops and many more things.

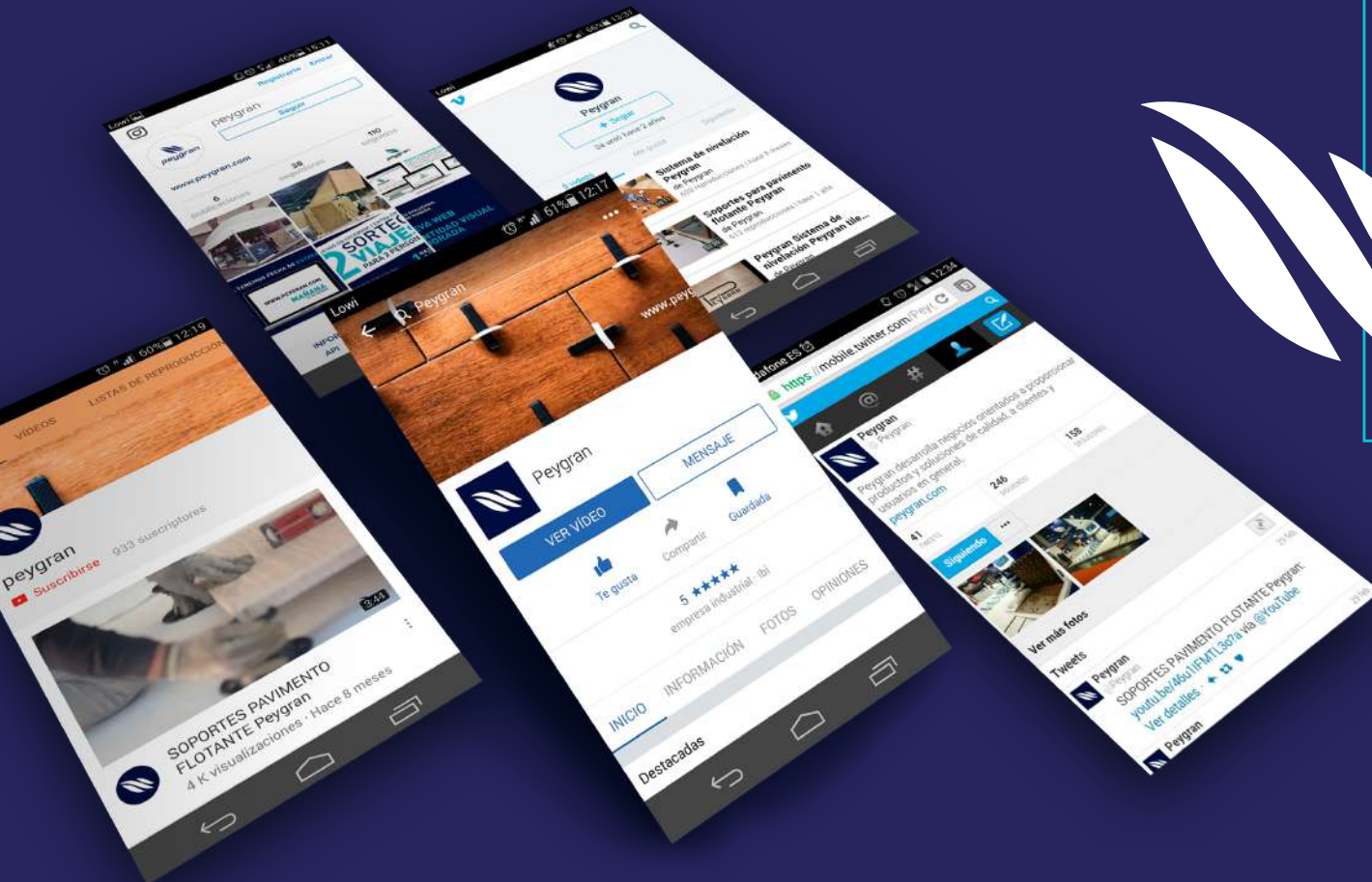

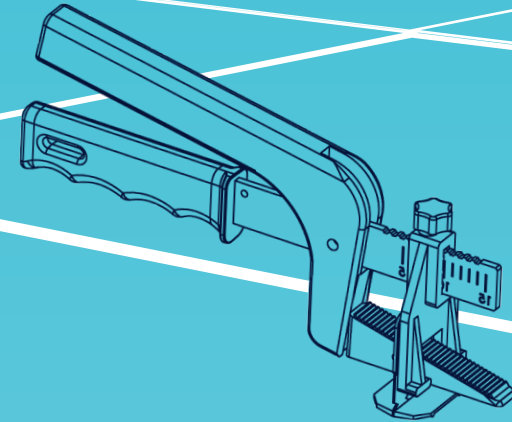
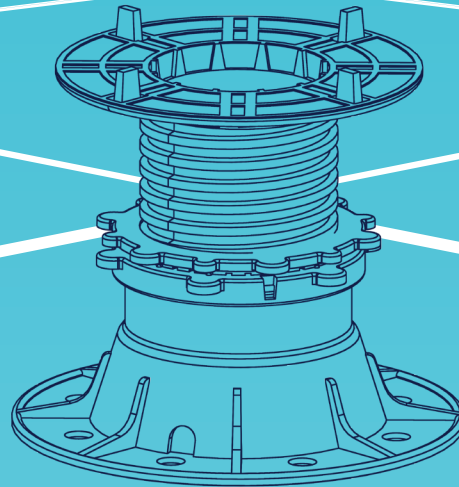
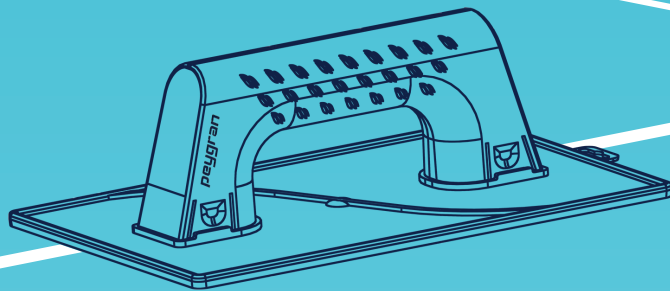
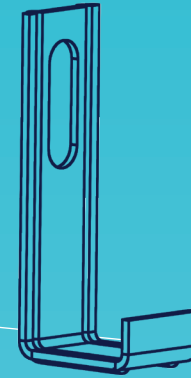
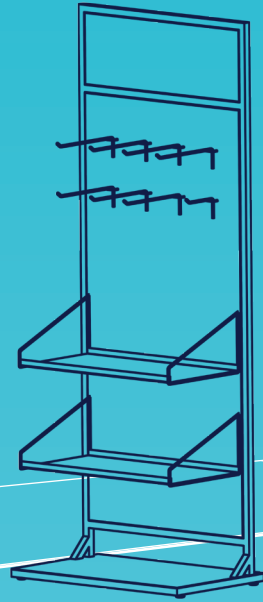



# FLOATS AND TROWELS

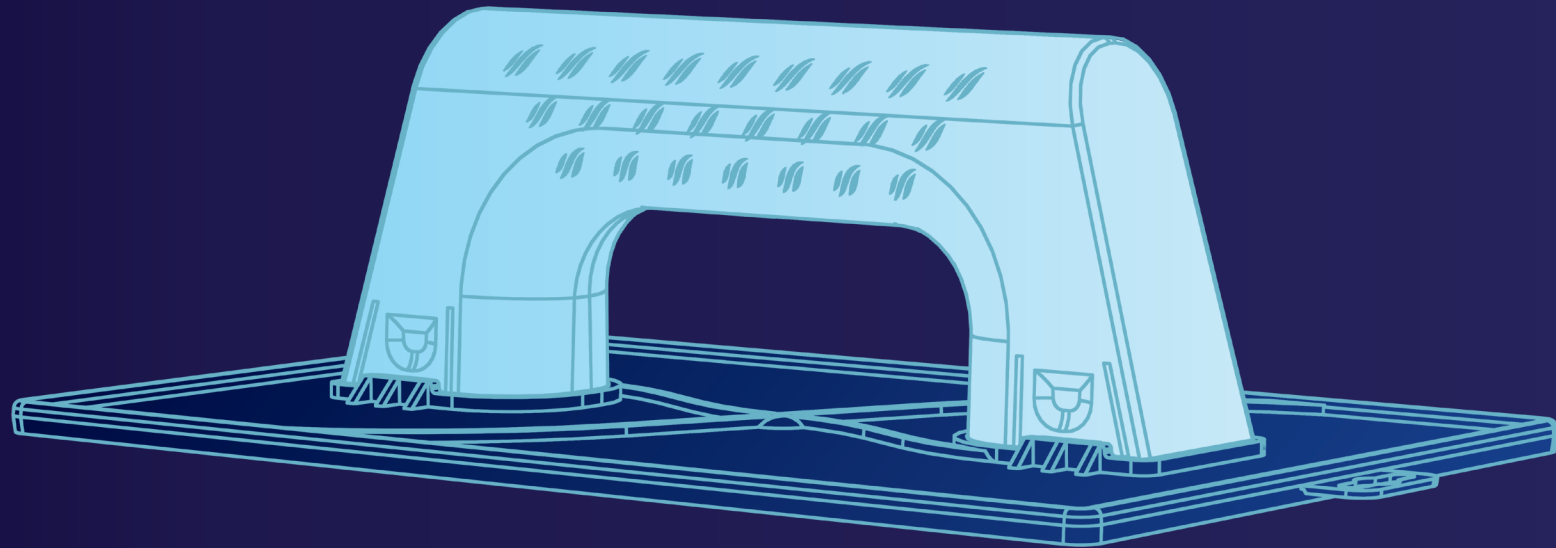



# Floats

We are showing our new range of floats and trowels with an ergonomic grip. Besides, float grips can be removed and different bases can be used.

Floats made of high-impact polystyrene. Trowels with polystyrene grip and steel and stainless steel base.

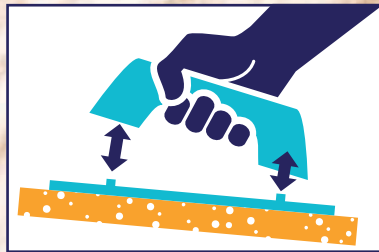

REUSABLE



LIGHT



ERGONOMIC



## Triple pack

The triple pack consists of an interchangeable grip with different combinations of our three types of interchangeable sponges.

- High Absorption
- Maximum Cleanliness
- Abrasion









Model	Characteristics
	<b>High Absorption.</b> Float with interchangeable sponge and ergonomic grip for finishing and cleaning surfaces with high absorption capacity.
	<b>Maximum Cleaning.</b> Float with replacement sponge with cuts and interchangeable. With an ergonomic grip for dragging dirt on surfaces easily.
	<b>Abrasion.</b> Sponge float suitable for persistent dirt on floors.

### Grouting Float

Rubber float with plastic ergonomic grip for optimum results in ceramics grouting.



Ref.	Description				Units (per box)	Box (cm)	Weight (kg)	
0300103	Peygran High Absorption Float	28x19x3 cm	0,327	100%	20	59x39x41	6,54	8425402085332
0300104	Peygran Maximum Cleaning Float	28x19x3 cm	0,327	80%	20	59x39x41	6,54	8425402085349
0300105	Peygran Abrasion Float	28x19x3 cm	0,327	50%	20	59x39x41	6,54	8425402085356
0300123	Peygran High Absorption Float SMALL	27x13x3 cm	0,220	100%	27	59x39x41	7,00	8425402085240
0300124	Peygran Maximum Cleaning Float SMALL	27x13x3 cm	0,220	80%	27	59x39x41	7,00	8425402085257
0300125	Peygran Abrasion Float SMALL	27x13x3 cm	0,220	50%	27	59x39x41	7,00	8425402085295
0300106	Peygran High Absorption Replacement	28x19x3 cm	0,202	100%	48	59x39x41	9,70	8425402085363
0300107	Peygran Maximum Cleaning Replacement	28x19x3 cm	0,202	80%	48	59x39x41	9,70	8425402085370
0300108	Peygran Abrasion Replacement	28x19x3 cm	0,202	50%	48	59x39x41	9,70	8425402085387
0300126	Peygran High Absorption Replacement SMALL	27x13x3 cm	0,100	100%	65	59x39x41	7,50	8425402085301
0300127	Peygran Maximum Cleaning Replacement SMALL	27x13x3 cm	0,100	80%	65	59x39x41	7,50	8425402085486
0300128	Peygran Abrasion Replacement SMALL	27x13x3 cm	0,107	50%	65	59x39x41	7,50	8425402085547
0300119	Triple Pack High Absorption	28x19x3 cm	0,707	100%	10	59x39x41	8,00	8425402085493
0300120	Triple Pack Maximum Cleaning	28x19x3 cm	0,707	80%	10	59x39x41	8,00	8425402085509
0300121	Triple Pack Abrasion	28x19x3 cm	0,707	50%	10	59x39x41	8,00	8425402085516
0300122	Triple Pack Combined	28x19x3 cm	0,707	-	10	59x39x41	8,00	8425402085523
0300117	Grouting Float	25x10 cm	0,279	-	45	46x39x40	13,50	8425402085479



# Plastic floats

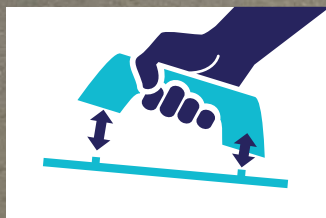

REUSABLE



LIGHT



ERGONOMIC



### Texture Float.

Interchangeable float with an ergonomic grip for floating texture surfaces.



### Smooth Float

Interchangeable float with an ergonomic grip for floating smooth surfaces.





### Pointed Float

Easy access to difficult areas.



### Flexible Float for Plasters

Perfect for the application and smoothing of plaster on walls.

Ref.	Description			Units (por box)	Box (cm)	Weight (kg)	
0300109	Peygran Straight Float with texture	27x18 cm	0,315	34	59x39x41	10,00	8425402085394
0300110	Peygran Straight Float, Smooth Base	27x18 cm	0,317	34	59x39x41	10,00	8425402085400
0300111	Peygran Straight Float Replacement with Texture	27x18 cm	0,151	150	46x39x40	23,00	8425402085417
0300112	Peygran Straight Float Replacement , Smooth Base	27x18 cm	0,153	150	46x39x40	24,00	8425402085424
0300129	Peygran Pointed Float	27x14 cm	0,230	34	59x39x41	9,00	8425402085554
0300130	Peygran Flexible Float for Plasters	30x14 cm	0,280	34	59x39x41	10,50	8425402085691
0300131	Peygran Pointed Float Replacement with Texture	27x14 cm	0,110	150	46x39x40	18,00	8425402085707
0300132	Peygran Flexible Peygran Yeso	30x14 cm	0,160	150	46x39x40	25,00	8425402089811



# Trowels

## Rectangular Trowel

Stainless Steel  
AISI 301



## Notched Trowel 8x8

Stainless Steel  
AISI 301



## Notched Trowel 10x10

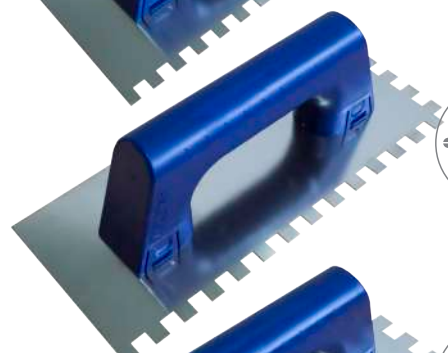

Stainless Steel  
AISI 301

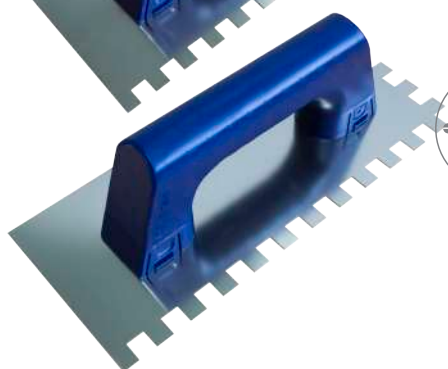

## Notched Trowel 12x12

Stainless Steel  
AISI 301



Ref.	Description		 Kg		Units (per box)	Box (cm)	Weight (kg)	
0300113	Peygran Rectangular Trowel	28x12 cm	0,390	-	32	59x39x41	13,50	8425402085431
0300114	Peygran Notched Trowel	27x12 cm	0,381	8x8	32	59x39x41	13,20	8425402085448
0300115	Peygran Notched Trowel	28x12 cm	0,381	10x10	32	59x39x41	13,20	8425402085455
0300116	Peygran Notched Trowel	29x12 cm	0,381	12x12	32	59x39x41	13,20	8425402085462



# Reusable grip

All our models of floats have a reusable grip.

Ergonomic and light grip with a special non-slipping texture.

Made of high-impact polystyrene. If you follow the recommended tips, it can be used on countless times. By doing this, we will achieve higher profitability and save storage space.

## Removing the grip

Press the flanges of a same side to remove the grip. When pressed, turn the grip and then, it will be released. Apply pressure on the grip flange with your hands and act as a lever with the other hand. Do the same on the other flange on the same side.



## Placing the grip

Rest the grip on the float base and insert the flanges by applying light pressure.



REUSABLE



LIGHT



ERGONOMIC

# TILE SPACERS AND OTHERS

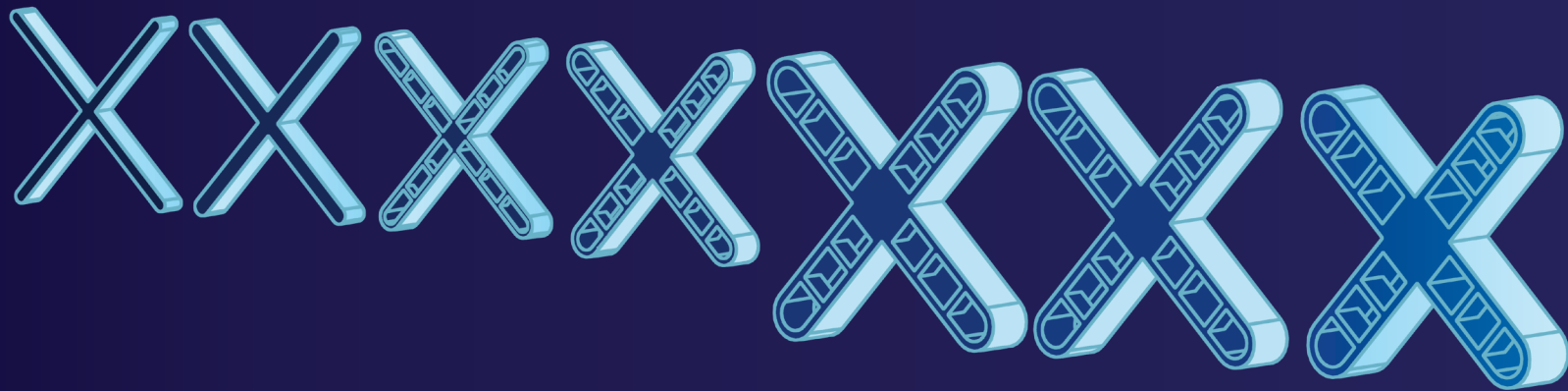



# Tile spacers





Tile spacers for highly resistant and precise tiling.

Our products range from 1 to 10 mm.

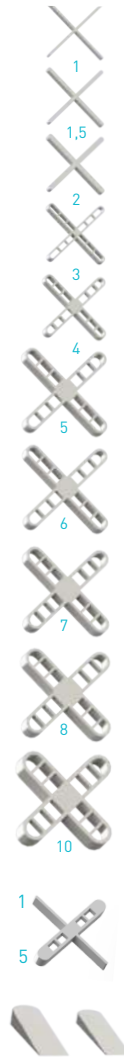
Tile spacers are made of a highly resistant material. Also reinforced and prepared to bear heavy tiles.

Wedges for tiling, 5 and 7.5 mm high. Made of shockproof polystyrene.



Ref.	Descrip.	mm (in)	Unds.	 Bags (per box)	 Box (cm)	 Weight (kg)	
0200058	Tile spacer	<b>1</b> (1/32")	300	170	59x39x41	10,18	8425402084854
0200076	Tile spacer	<b>1</b> (1/32")	1.000	50	59x39x41	10,00	8425402084861
0200079	Tile spacer	<b>1,5</b> (1/16")	300	150	59x39x41	10,30	8425402084878
0200060	Tile spacer	<b>2</b> (3/32")	300	140	59x39x41	15,28	8425402084885
0200075	Tile spacer	<b>2</b> (3/32")	1.000	45	59x39x41	17,00	8425402084892
0200061	Tile spacer	<b>3</b> (1/8")	300	120	59x39x41	17,32	8425402084908
0200074	Tile spacer	<b>3</b> (1/8")	1.000	40	59x39x41	18,13	8425402084915
0200062	Tile spacer	<b>4</b> (5/32")	300	80	59x39x41	13,16	8425402084922
0200073	Tile spacer	<b>4</b> (5/32")	800	30	59x39x41	13,10	8425402084939
0200063	Tile spacer	<b>5</b> (3/16")	200	90	59x39x41	14,95	8425402084946
0200072	Tile spacer	<b>5</b> (3/16")	500	35	59x39x41	14,56	8425402084953
0200064	Tile spacer	<b>6</b> (1/4")	100	100	59x39x41	12,40	8425402084960
0200089	Tile spacer	<b>6</b> (1/4")	300	36	59x39x41	13,24	8425402084977
0200065	Tile spacer	<b>7</b> (9/32")	100	75	59x39x41	15,80	8425402084984
0200090	Tile spacer	<b>7</b> (9/32")	300	25	59x39x41	14,32	8425402084991
0200066	Tile spacer	<b>8</b> (5/16")	50	100	59x39x41	10,30	8425402085004
0200091	Tile spacer	<b>8</b> (5/16")	200	30	59x39x41	12,16	8425402085011
0200067	Tile spacer	<b>10</b> (13/32")	50	100	59x39x41	15,70	8425402085028
0200093	Tile spacer	<b>10</b> (13/32")	150	30	59x39x41	14,05	8425402085035
0200080	Double Tile spacer	<b>1 y 5</b> (1/32") (3/16")	200	90	59x39x41	9,72	8425402085073
0200077	Wedge	<b>5</b> (3/16")	500	50	59x39x41	12,00	8425402085042
0200078	Wedge	<b>7,5</b> (19/64")	500	50	59x39x41	19,00	8425402085059





# Peygran Box Tile spacers



The new Peygran Box packaging improves the product image in the stores. This new packaging optimises the display and arrangement of the product making it more visible. Stackable format to have all components tidy and sorted. The front window or the top part can be removed to have the product more visible.

The amount of bags contained varies according to the dimensions of the tile spacers.

Totem format allows us to display all the possible dimensions of tile spacers in an organised way and can be placed everywhere without using shelves

Ref.	Description	mm (in)	Bags	Weight	Units (per box)	Box (cm)	Weight (kg)	Barcode
0300091	P. Box Tile spacers 1	<b>1</b> (1/32")	52 x 300	3,20 kg	1	46x40x39	4,20	8425402089651
0300092	P. Box Tile spacers 1,5	<b>1,5</b> (1/16")	52 x 300	3,61 kg	1	46x40x39	4,61	8425402089668
0300093	P. Box Tile spacers 2	<b>2</b> (3/32")	40 x 300	4,47 kg	1	46x40x39	5,47	8425402089675
0300094	P. Box Tile spacers 3	<b>3</b> (1/8")	40 x 300	5,83 kg	1	46x40x39	6,83	8425402089682
0300095	P. Box Tile spacers 4	<b>4</b> (5/32")	30 x 300	4,95 kg	1	46x40x39	5,95	8425402089699
0300096	P. Box Tile spacers 5	<b>5</b> (3/16")	30 x 200	5,04 kg	1	46x40x39	6,04	8425402089705
0300097	P. Box Tile spacers 6	<b>6</b> (1/4")	35 x 100	4,38 kg	1	46x40x39	5,38	8425402089712
0300098	P. Box Tile spacers 7	<b>7</b> (9/32")	29 x 100	4,68 kg	1	46x40x39	5,68	8425402089729
0300099	P. Box Tile spacers 8	<b>8</b> (5/16")	40 x 50	4,11 kg	1	46x40x39	5,11	8425402089736
0300100	P. Box Tile spacers 10	<b>10</b> (13/32")	25 x 50	4,06 kg	1	46x40x39	5,06	8425402089743
0300101	P. Box Wedges 5	<b>5</b> (3/16")	40 x 500	9,60 kg	1	46x40x39	10,60	8425402089750
0300102	P. Box Wedges 7,5	<b>7,5</b> (19/64")	40 x 500	15,40 kg	1	46x40x39	16,40	8425402089767



# 4 MULTI SERIES





Our Multi-Series works as a set of tile spacers. We can separate in X, T o –.

Each model has 4 separation measures (1,2,3 y 5 mm).

Made of high quality resistant material, especially suitable for large formats and heavy slabs. This is a recoverable and reusable piece.



**1, 2, 3 y 5 mm**  
**1/32" - 3/32" - 1/8" - 3/16"**

Ref.	Description	Units	 Bags (per box)	 Box (cm)	 Weight (kg)	
0200081	Multi <b>Spacer</b> 4x (1/2/3/5mm)	125	18	46x40x39	8,00	8425402085080
0200082	Multi <b>T</b> 4x (1/2/3/5mm)	80	18	46x40x39	7,00	8425402085097
0200083	Multi <b>X</b> 4x (1/2/3/5mm)	60	18	46x40x39	6,70	8425402085103



**4**  
**x** MULTI  
SPACER



2 mm  
3/32"      1 mm  
1/32"



3 mm  
1/8"      5 mm  
3/16"

**4**  
**x** MULTI  
T



2 mm  
3/32"      1 mm  
1/32"



3 mm  
1/8"      5 mm  
3/16"

**4**  
**x** MULTI  
X



2 mm  
3/32"      1 mm  
1/32"



3 mm  
1/8"      5 mm  
3/16"



**Visit our videos**

A picture is worth a thousand words.



Video *MODE OF USE*





# Other products



## Conix Round Guardrail

Built-in / registrable base capsule for handrails or guardrails

Ref.	Description	Units	Barcode
3000021	Conix Round Guardrail	100	8425402085721

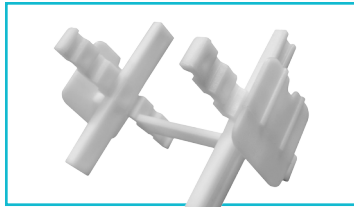

## Glass-block Tile spacer

Glass-block tile spacers.

Ref.	Description	Units	Barcode
3000022	Glass-block Tile spacer	300	8425402085738

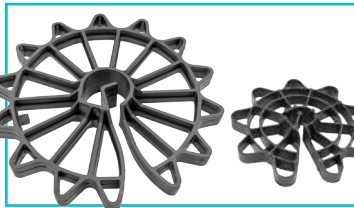

## Rudder Spacer 30 or 50

Rudder spacers for frames in vertical slab.

Ref.	Description	Units	Barcode
3000023	Rudder Spacer 30	500	8425402085745
3000024	Rudder Spacer 50	100	8425402085752



## Mushroom

Protectors-signallers for corrugated rods.

Ref.	Description	Units	Barcode
3000020	Mushroom	300	8425402085714



## Grouting Sleeve

Sleeve for mortar grouting with precision nozzle for narrow joints.

Ref.	Description	Units	Barcode
0200202	Grouting Sleeve	1	8425402085110

# LEVELLING SYSTEM

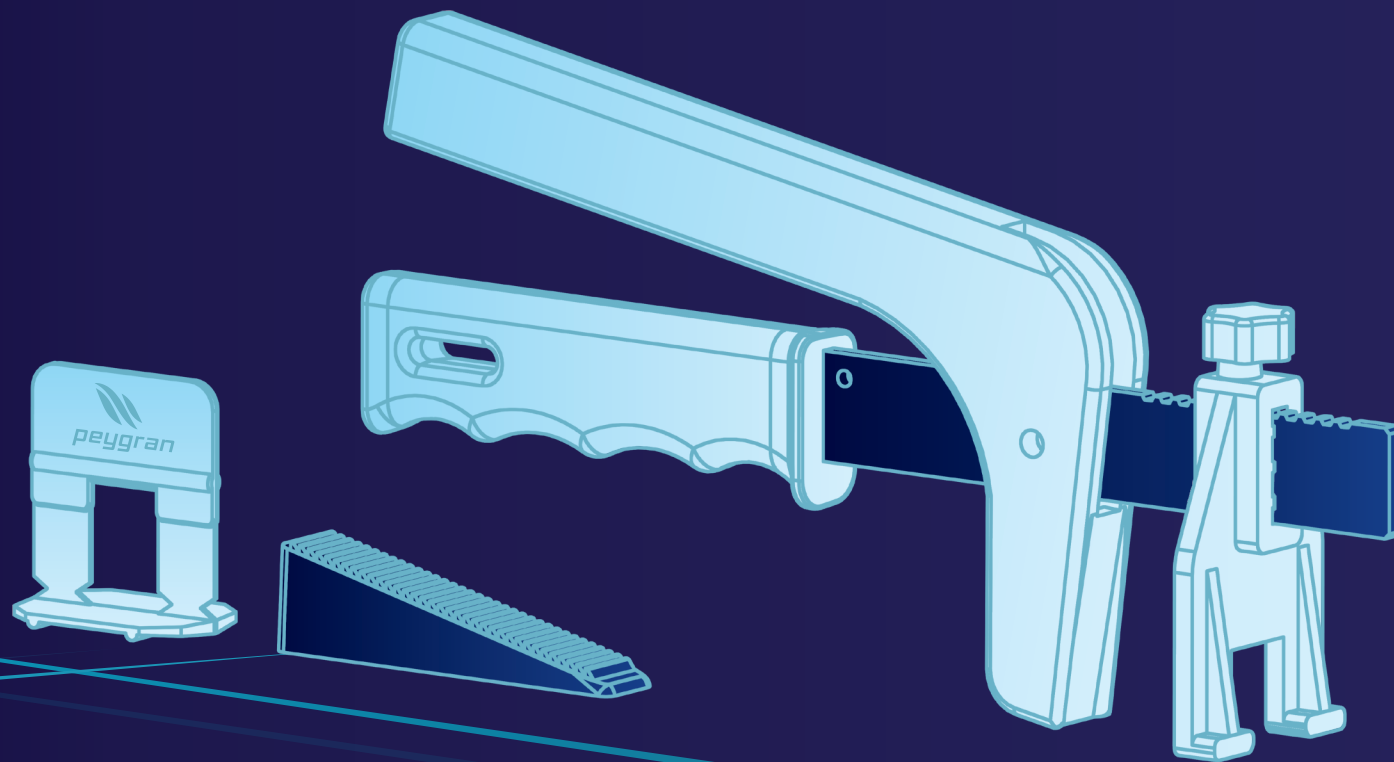



# LEVELLING SYSTEM

Peygran® levelling system ensures flatness between tiles avoiding movements during the mortar setting.

This reduces the time for the ceramic laying obtaining a perfect lippage-free finish.

A fast and 100% effective tool.

Clip  
**0,5**  
mm  
(1/51")



## WE LAUNCH A NEW CLIP!

The thinnest joint on the market, with perfect breakage guarantee.



Reduces laying time



Ensures flatness between tiles and avoids movements due to mortar setting



Minimum joint less than 1mm  
Available for 1, 2 and 3 mm



Range of use: from 3 to 30 mm



Video MODO DE USO  
Video MODE OF USE



# Clips and wedges



Ref.	Description	mm(in)	Units	Bags (per box)	Box (cm)	Weight (kg)	
<b>0,5mm Clips (1/51")</b>							
0200320	Clip	<b>0,5</b> (1/51")	100	30	59x39x41	16,50	8425402089828
0200321	Clip	<b>0,5</b> (1/51")	300	12	59x39x41	19,80	8425402089835
0200325	Clip	<b>0,5</b> (1/51")	500	8	59x39x41	23,00	8425402089880
<b>1mm Clips (1/32")</b>							
0200112	Clip	<b>1</b> (1/32")	100	30	59x39x41	16,50	8425402085189
0200094	Clip	<b>1</b> (1/32")	300	12	59x39x41	19,80	8425402085165
0200118	Clip	<b>1</b> (1/32")	500	8	59x39x41	23,00	8425402085592
<b>2mm Clips (1/16")</b>							
0200114	Clip	<b>2</b> (1/16")	100	30	59x39x41	16,50	8425402085202
0200113	Clip	<b>2</b> (1/16")	300	12	59x39x41	19,80	8425402085196
0200136	Clip	<b>2</b> (1/16")	500	8	59x39x41	23,00	8425402085578
<b>3mm Clips (1/8")</b>							
0200116	Clip	<b>3</b> (1/8")	100	30	59x39x41	16,50	8425402085226
0200115	Clip	<b>3</b> (1/8")	300	12	59x39x41	19,80	8425402085219
0200137	Clip	<b>3</b> (1/8")	500	8	59x39x41	23,00	8425402085561
<b>Wedges</b>							
0200110	Levelling wedge	-	100	37	59x39x41	24,90	8425402085172
0200092	Levelling wedge	-	300	12	59x39x41	24,90	8425402085158
0200277	Levelling wedge	-	500	8	59x39x41	28,00	8425402085585

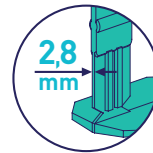
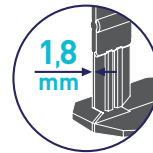
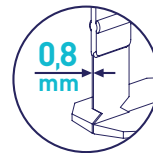
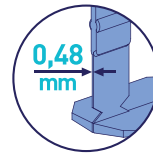

Tol: +0,04  
-0,01



## Which clip do you need? According to the tile thickness

Ceramic thickness

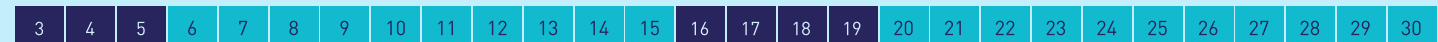

Ceramic clip  
+ wedge-base



Ceramic clip



Stone clip  
+ wedge-base



Stone clip



# Pliers for ceramics

The main characteristic is its scale bar for the ceramics thickness (patented system). The scale bar allows us to adjust the tool to the pressure needed easily, quickly and effectively.

If higher pressure is needed, the tool can be adjusted one more point without causing the clip breakage or any other inconvenience.

The parts in contact with the tile are made of plastic to avoid damages.

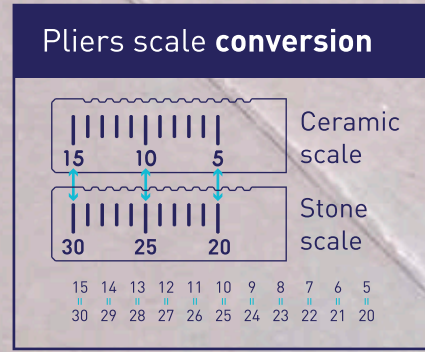
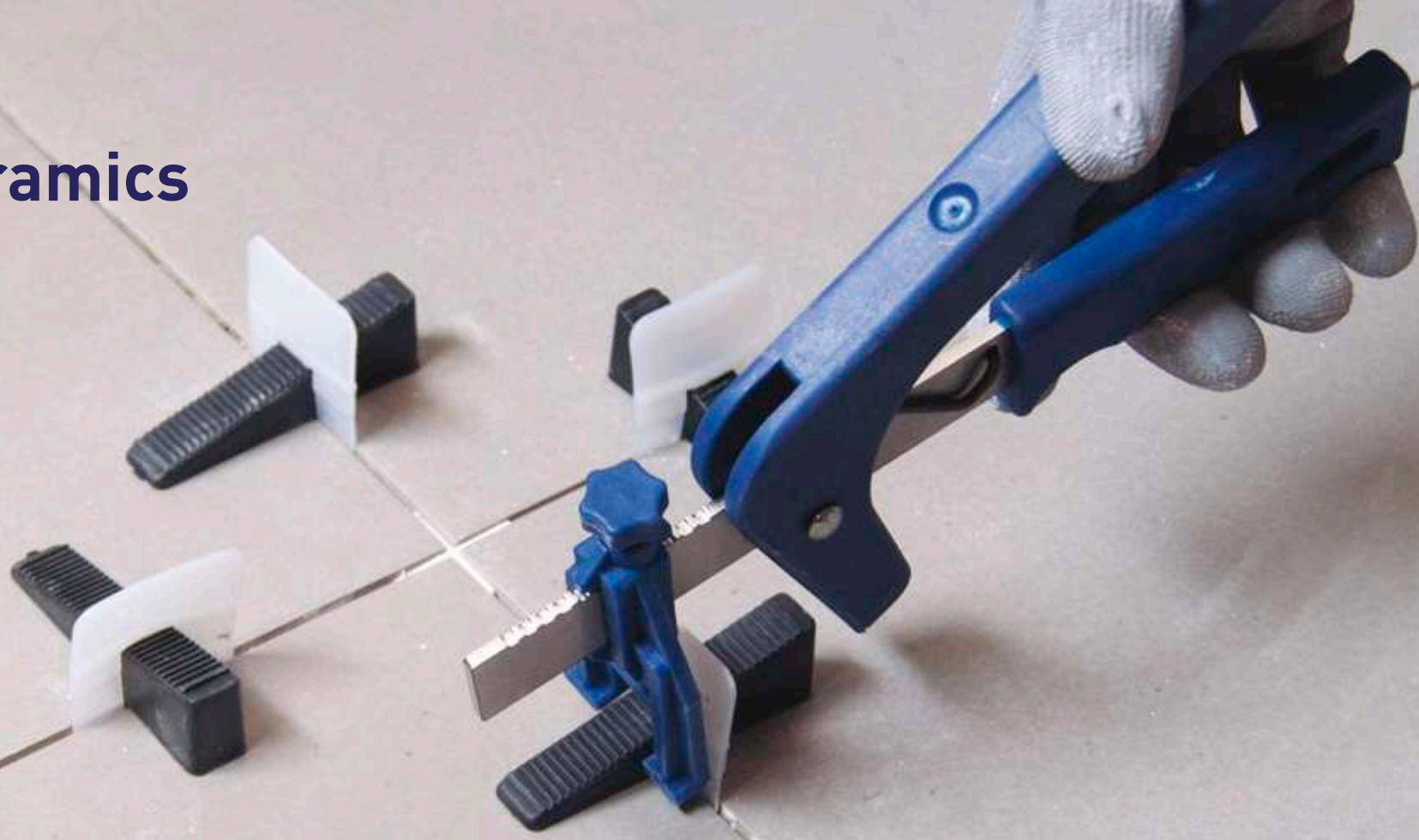

Ref.	Description	mm	Units	Weight	Units (per box)	Box (cm)	Weight (kg)	
0200117	Pliers for ceramics	3-15	1	0,23 kg	70	46x40x39	17	8425402085233





# Clips and pliers for stone

Clips for stone have been specifically designed for granite, stone and marble. Allow us to work between 17 and 30mm. More resistant than the usual crosshead in order to adjust heavy formats. Between 17 and 20 mm, use it together with the special wedge-base to ensure tightening.

Pliers for stone have the same characteristics as pliers for ceramics. The only difference is the reference measures on the scale bar, which are for stone measures.

Pliers can be used up to 30mm.



Ref.	Description	mm	Units	Weight	Units (/Box)	Box (cm)	Weight (kg)	Barcode
0200140	Pliers for stone	16-30	1	0,23 kg	70	46x40x39	17	8425402085141

Ref.	Description	mm	Units	Bags (/Box)	Box (cm)	Weight (kg)	Barcode
0200141	Clip for stone	1	80	30	46x40x39	12,50	8425402085325
0200139	Clip for stone	1	300	9	59x39x41	17	8425402085134



# Wedge-base

Wedge-bases have been made to extend the functionalities of our system allowing us to work with thicknesses from 3 to 5mm. Use it in thicknesses lower than 5 mm and in thicknesses from 17 to 20mm.

Place the clips under the wedge, allowing the wedge to be centered and providing a larger support surface.

Essential in cladding as they are very delicate pieces. **When using it on the tool scale bar, add 4 mm to the piece thickness.**



## We will use it in:

Thicknesses less than 5mm (together with the ceramic cross-head)

And thicknesses between 17 and 20 mm (together with the stone crosshead)

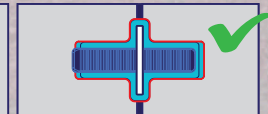
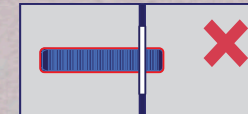
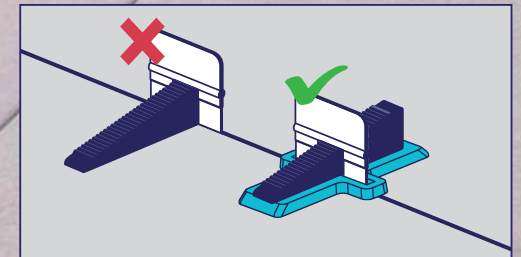

The wedge is not resting appropriately on one of the tiles.

Larger and better support surface for both tiles.

Ref.	Description	Units
0200095	Wedge-base	100

  

Bags (/Box)	Box (cm)	Weight (kg)	
40	59x39x41	56,90	
8425402085318			

## Which clip do you need? According to the tile thickness

Ceramic thickness

3	4	5	6	7	8	9	10	11	12	13	14	15	16	17	18	19	20	21	22	23	24	25	26	27	28	29	30
---	---	---	---	---	---	---	----	----	----	----	----	----	----	----	----	----	----	----	----	----	----	----	----	----	----	----	----

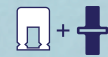

Ceramic clip + wedge-base



Ceramic clip



Stone clip + wedge-base



Stone clip



# Levelling System Protection Plate

Specially designed to protect the tiles (especially in the case of delicate ceramics and fine thickness) when using the Peygran Levelling System.

The protection plate is placed under the wedge to achieve a perfect finish, eliminating the friction in the strength of the material and converting the lateral force into vertical pressure, preventing the mortar from squeezing up through the grout joints.

Avoids delicate materials such as natural stone or glass from scratching and also avoids the premature wear of the components.

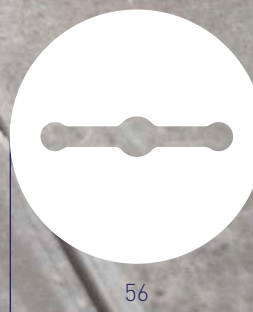

Ref.	Descripción	uds.
0200322	Levelling System Protection Plate	100



8425402089842



# Kits

## Ceramics / Stone



### The 100 Kit ceramics / stone

Specially designed to get started on the use of the tile levelling system.

### The 400 Kit ceramics / stone





Specially designed to install the tile levelling system in bigger rooms.

 x 100  
 x 100



We can install a 3x3m room with 65x65cm tiles.





- NEW**  
 **0,5mm**  
 (1/51")
-  **1 mm**  
 (1/32")
-  **2mm**  
 (1/16")
-  **3mm**  
 (1/8")



- Content**
-  x 1
  -  x 400
  -  x 200

### Kit for ceramics



Ref.	Description	mm (in)	Weight	kits (/Box)	Box (cm)	Weight (kg)	Barcode
0200323	Kit for ceramics 100 Units	0,5 (1/51")	1,50 kg	12	59x52x41	19	8425402089859
0200120	Kit for ceramics 100 Units	1 (1/32")	1,50 kg	12	59x52x41	19	8425402085264
0200121	Kit for ceramics 100 Units	2 (1/16")	1,50 kg	12	59x52x41	19	8425402085271
0200122	Kit for ceramics 100 Units	3 (1/8")	1,50 kg	12	59x52x41	19	8425402085288
0200324	Kit for ceramics 400 Units	0,5 (1/51")	3,85 kg	4	59x52x41	16,5	8425402089866
0200150	Kit for ceramics 400 Units	1 (1/32")	3,85 kg	4	59x52x41	16,5	8425402085653
0200151	Kit for ceramics 400 Units	2 (1/16")	3,85 kg	4	59x52x41	16,5	8425402085660
0200152	Kit for ceramics 400 Units	3 (1/8")	3,85 kg	4	59x52x41	16,5	8425402085677



-  **kits**  
(/Box)
-  **Box**  
(cm)
-  **Weight**  
(kg)
- 

-  **STONE**



- Content**
-  x 1
  -  x 380
  -  x 200

### Kit for stone

Ref.	Description	mm (in)	Weight	kits (/Box)	Box (cm)	Weight (kg)	Barcode
0200138	Kit for stone 80 Units	1 (1/32")	1,46 kg	12	59x52x41	18,5	8425402085127
0200153	Kit for stone 380 Units	1 (1/32")	3,60 kg	4	59x52x41	15,5	8425402085684



-  **kits**  
(/Box)
-  **Box**  
(cm)
-  **Weight**  
(kg)
- 



# Peygran Box Levelling System

The new Peygran Box packaging improves the product image in the stores. This new packaging optimises the display and arrangement of the product making it more visible. Stackable format to have all components tidy and sorted.

Each Peygran Box contains 12 bags of 100 units, both Clips (1-2-3mm) and Wedges.

The Totem format allows us to display all dimensions of Clips in an organised way, and can be placed everywhere without using shelves.

**Peygran Box Leveling System:**  
12 bags of 100 units (crossheads or wedges)



**Totem L. System:**  
(8 Peygran Box System)



Ref.	Description	mm (in)	Units	Weight	Units (/Box)	Box (cm)	Weight (kg)	Barcode
0200128	Peygran Box L.System Clip 0,5	0,5 (1/51")	12 x100	3,00 kg	1	46x40x39	4,00	8425402089873
0200123	Peygran Box L.System Clip 1	1 (1/32")	12 x100	3,00 kg	1	46x40x39	4,00	8425402089655
0200124	Peygran Box L. System Clip 2	2 (1/16")	12 x100	3,00 kg	1	46x40x39	4,00	8425402089662
0200125	Peygran Box L. System Clip 3	3 (1/8")	12 x100	3,00 kg	1	46x40x39	4,00	8425402089679
0200126	Peygran Box L. System wedge	-	12 x100	3,31 kg	1	46x40x39	4,31	8425402089686
0200127	Peygran Box L. System Clip stone	1 (1/32")	12 x 80	3,73 kg	1	46x40x39	4,73	8425402085530



# ADVANTAGES

Ensures flatness between tiles.



## Indispensable for:

Rectified ceramics, porcelain tiling and large formats.

## Recommended for:

Marble, granite, stone and ventilated façades

Reduces laying time.



Prevents pieces from owing due to the mortar setting.

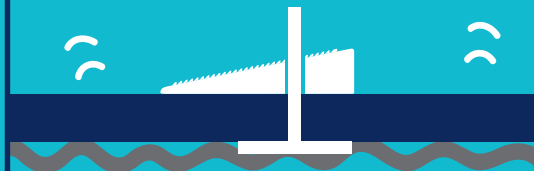

Highly useful in tiling, cladding and ventilated façades.



Recommended for formats from 30x30 cm. Indispensable for large formats.



Minimum joint lower than 1mm. Available in 0,5, 1, 2 and 3mm thick.



Range of use: from 3 to 30 mm thick.

3 mm.



30 mm.



# HOW TO USE



## 1° SET THE PLIERS

Set the pliers to the scale according to the ceramics thickness.



## 2° PLACE THE CROSSHEAD

Spread the glue cement and then lay the first tile at the level. Introduce the clip at the ends of the tile. (approx. 50mm).



## 3° INTRODUCE THE WEDGES

When laying the adjacent tiles, introduce the wedges in the clips manually.



## 4° TIGHTEN

Rest the pliers as shown in the image and tighten to the maximum to level the tiles before the glue sets.



## 5° TAP GENTLY

When the tile is levelled, we recommend hitting gently to release tensions.



## 6° ALLOW FOR SETTING

When the surface is finished, allow the glue to set for the time recommended by the manufacturer.



## 7° REMOVE THE SYSTEM

After the necessary time, remove the clips by hitting on them with a rubber mallet or with your foot in the direction of the joint (do not hit the wedges). The clip will always break by the side cuts, under the tile



## 8° REUSABLE WEDGES

Finally, remove the wedges, the rest of the clip and grout the tiles.





# Tips

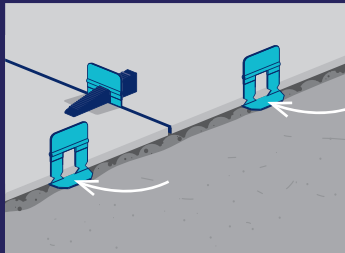

**If laying is not finished at the end of the working day and will be continued the following day:**

Be sure to remove the fixing material or mortar on the last row of tiles by using the base of a clip to leave a small gap to allow you to insert the clip base the following day.

The following day: fill the gaps left the day before with a trowel for edges and "fill" the back of the tile with mortar. Insert the clips and wedges and continue laying following the same process.

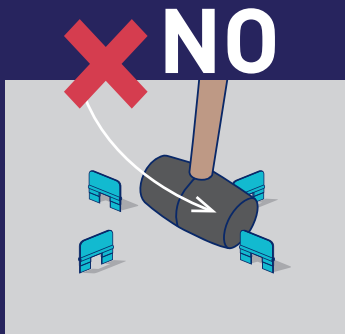

**Do not remove the wedges manually before breaking the system.**

The clip must be under tension to break correctly. If wedges are removed earlier, such tension will be eliminated and thus not correctly broken. If not breaking appropriately, as previously described, pull the clip with the pliers. It will break on the pre-factures and consequently, under the tile. Wedges can be reused.

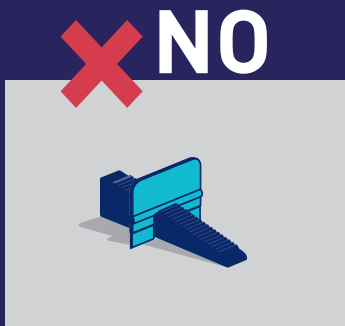

**Never install the levelling system at the tile corners.**

Installation will become more difficult, tile may break if tightened at the corner, apart from being very difficult to maintain the grout joint aligned.

# How many pieces do you need?

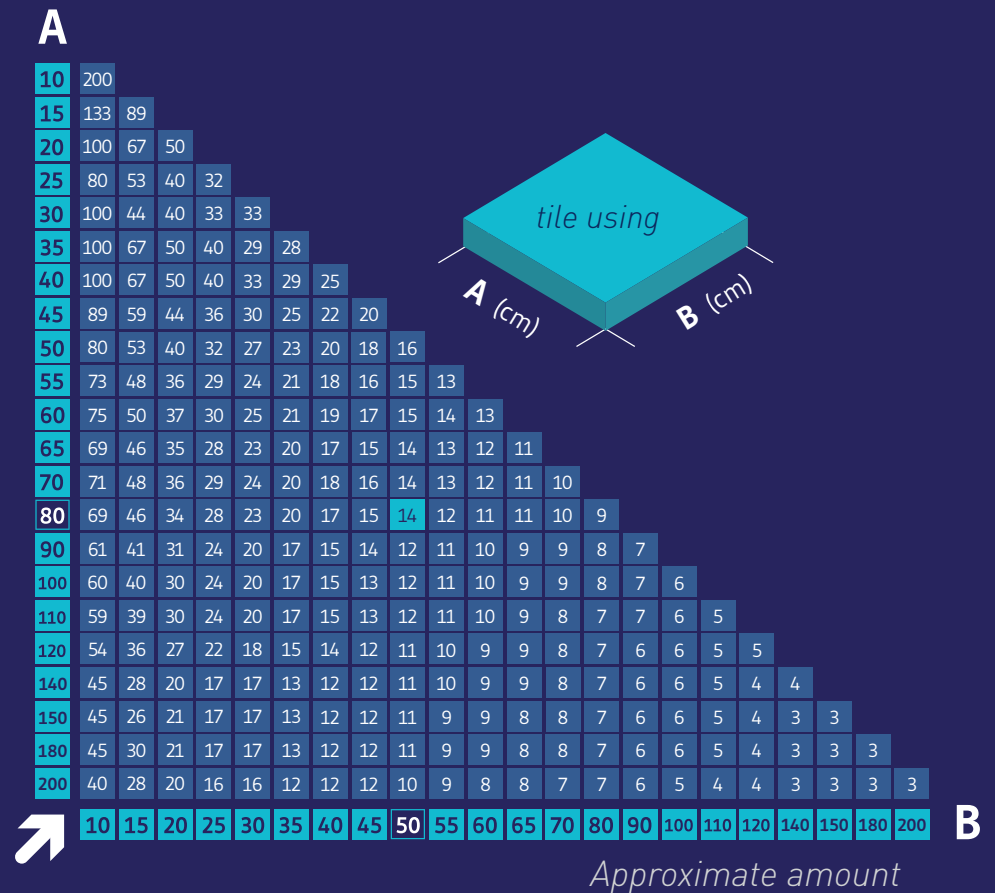



# CLADDING FACADE ANCHORS

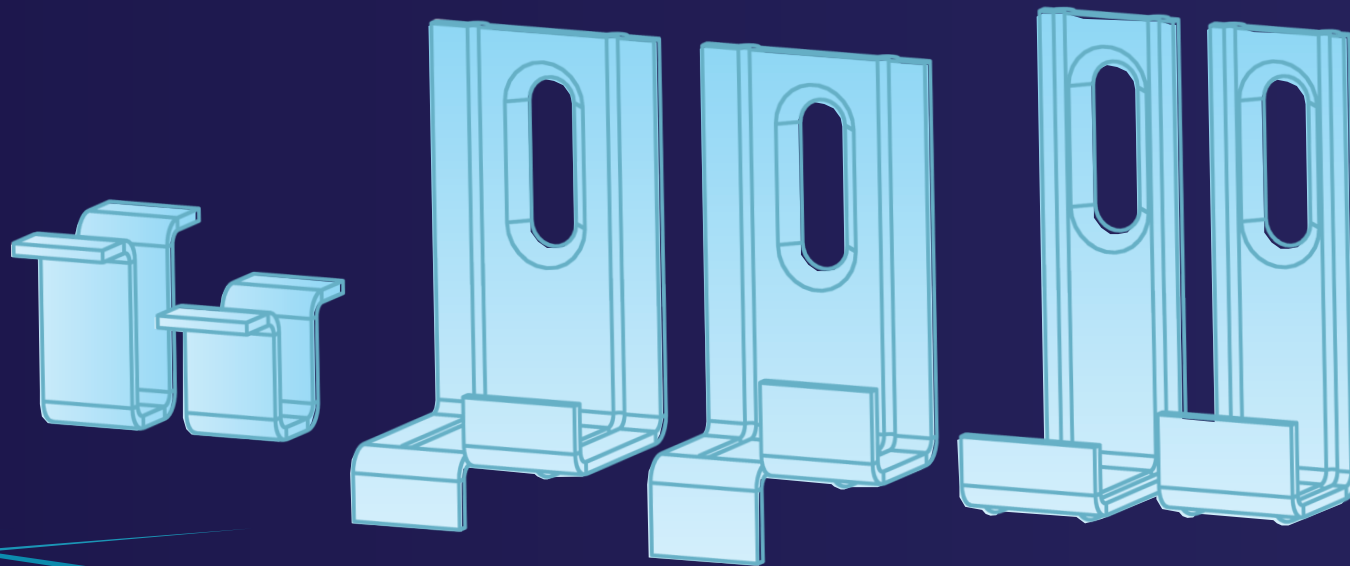



# Cladding Facade Anchors

According to the present regulations, it is mandatory to wedge-base mortar-glued façades with mechanical fixing elements.

With these elements, tile detachment, as a consequence of the course of time and atmospheric agents, is avoided; the glue loses its adhesive properties.

Our safety clamps made of stainless steel are recommended as an additional safety measure against the risk of fall.



Great resistance to risk of fall



Higher resistance to atmospheric agents



Allows for a wider range of tile formats mayor



Allows for great variety of finishes



Easy to install and light weight

**Available lacquering**

WHITE

RAL 1013

RAL 7012

RAL 9005

 Improves the appearance of your facade merging the tone of the clamp with the tile.  
 Specific colours: ask about.

**Box**  
*(cm)*
**Weight**  
*(kg)*
**Ref.**
**Description**
**mm**  
 joint

**Units**

Ref.	Description	mm joint	Diagram	Units	Box (cm)	Weight (kg)
<b>Start Clamp</b>						
0200300	Start Clamp EXPOSED	-	15 6	500	28x19x17	4,45
0200303	Start Clamp HIDDEN	-	10 8	500	28x19x17	4,30
<b>Intermediate Clamp</b>						
0200302	Intermediate Clamp EXPOSED	2	15 6	500	28x19x17	6,07
0200304	Intermediate Clamp HIDDEN	2	10 8	500	28x19x17	5,54
<b>Omega Clamp</b>						
0200301	Omega Clamp EXPOSED	8	15 6	1.000	28x19x17	5,59
0200305	Omega Clamp HIDDEN	8	10 8	1.000	28x19x17	4,97
<b>Z Clamp</b>						
0200315	Z Clamp	3	- -	1.000	28x19x17	8,47

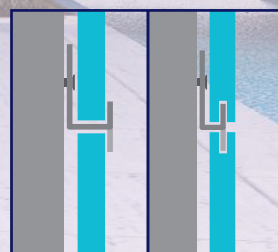
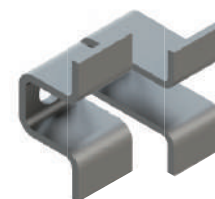
**GRAPA VISTA**
**GRAPA OCULTA**

 Models Start and Intermediate include: 3,5 x 40 mm screw and 6 x 30 mm plug  
 Models Omega: 3 x 35 mm screw and 5 x 25 mm plug



# NEW SERVICE

**We offer an optional service for lacquering exposed clamps.**

In this way we greatly improve the final finish of the facade as the unwanted vision of clamps on many facades, because of tones and reflections, is eliminated.

Choose the color that better matches your facade and ask for it when placing your order. Minimum order 1.000 units.

## Ask your color

Special colors consult +34 966 550 514

### Available lacquering



Improves the appearance of your facade merging the tone of the clamp with the tile.

## CALCULATOR Peygran

**Automatic calculation of the anchors you need in your facade.**

With our Peygran Calculator software, you will be able to calculate the number and type of anchors for cladding facades that you will need for your project.

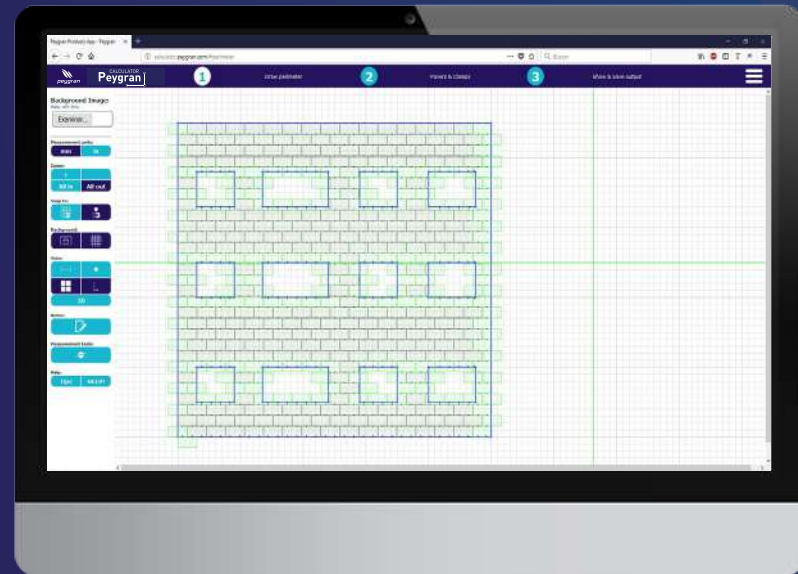

[www.peygran.com](http://www.peygran.com)



**CALCULATE  
NOW**

# RAISED FLOOR PEDESTALS

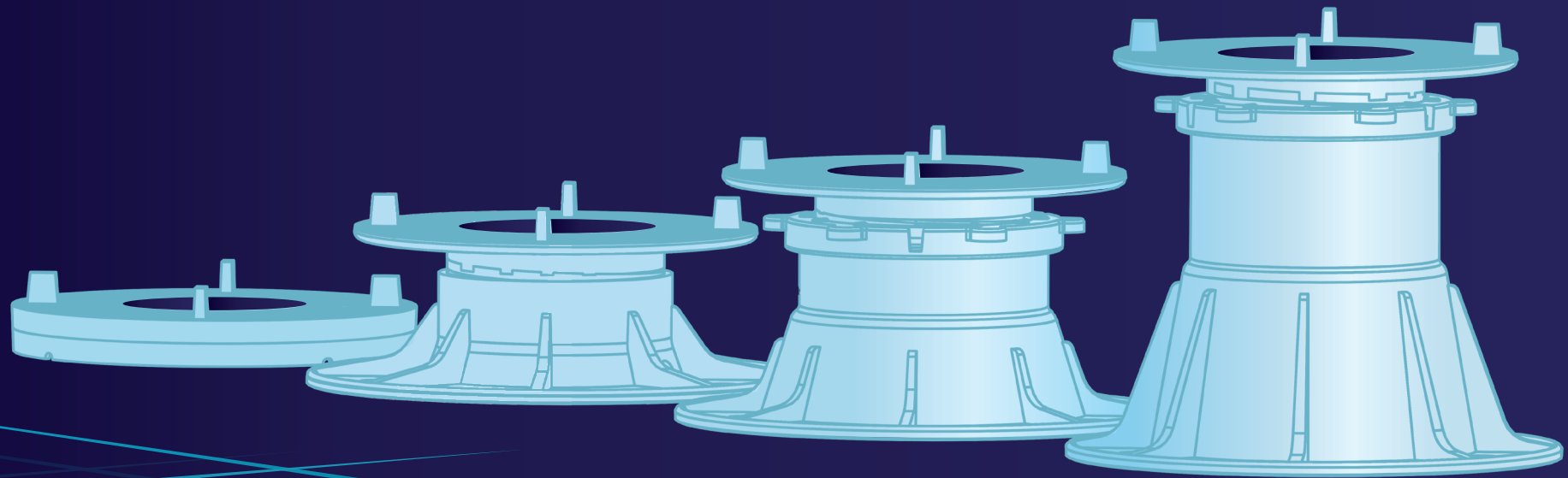



# Raised floor Pedestals

Peygran Pedestals for external use are a solution for projects in which floating, technical, raised or registrable floors are needed.

The only alternative to traditional construction methods in this type of projects in order to reduce weight and avoid architectural barriers.

Allow for high quality finish saving work and making further maintenance easier.







## Applications

- Covers in flat roofs
- Pool edges and planking
- Covered pedestrian passages and gardens
- Raised, floating and technical floors
- Illuminated floors
- Canopies, stands, etc.

# ADVANTAGES

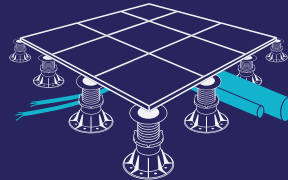

**1** Easy installation of pipes and wires

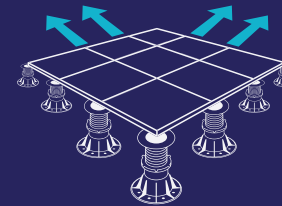

**2** Acts as an expansion joint

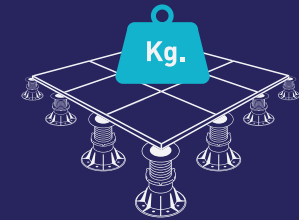

**3** Passable pavement resistant to passing

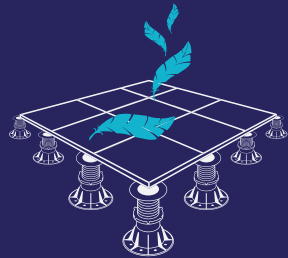

**4** Light covers

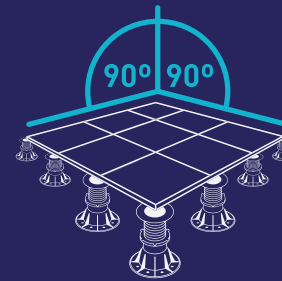

**5** Complete flatness of the floor

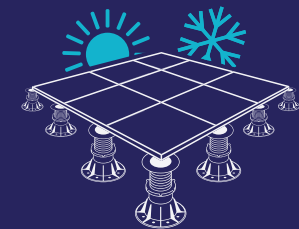

**6** Optimal thermal insulation



**7** Perfect water disposal

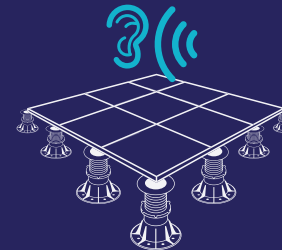

**8** Greater acoustic insulation

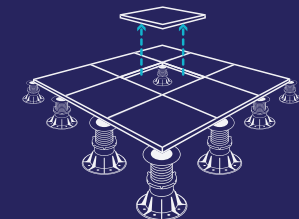

**9** Entirely registrable raised floor





# HOW TO USE



## 1° Place first Pedestals

Place 4 Pedestals adjusted to the tile width. Start by a corner of the perimeter to install.

Break the Pedestal flanges that hamper the appropriate tile installation.



## 2° Level the tile

Use a leveller to check the appropriate levelling of the tile on the Pedestals. Adjust the Pedestals with the floating nut until reaching the wanted height and complete levelling.

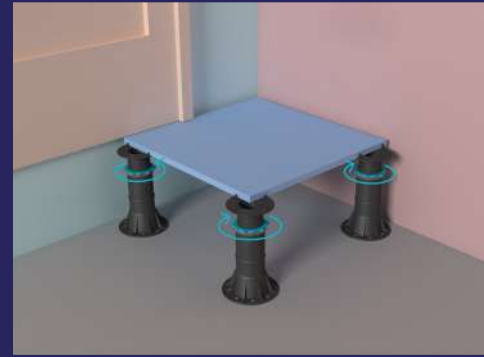

## 3° Fix the Pedestal

Tighten the locknut for fixing the Pedestal completely and avoid movements. We recommend fixing the base with polyurethane foam or similar. In this way unwanted movements are avoided.



## 4° Place the following Pedestals

Place the following Pedestals for the adjacent tiles.

We also recommend using pads to damper sound.

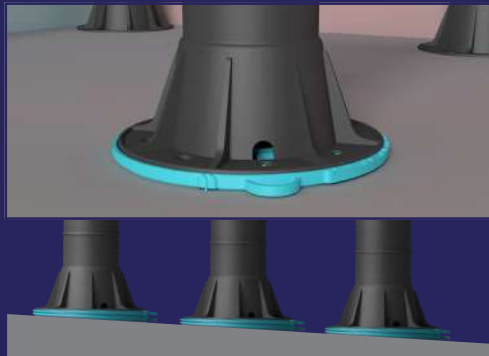

## 5° Compensate unevenness (Slope Regulator)

For a completely levelled surface, use a slope regulator to compensate the floor unevenness.



## 6° Lay the adjacent tiles

Lay the tiles orderly adjusting the floor to the Pedestal flanges, in this way, avoiding further spaces and movements unwanted.



## 7° Continue levelling

Continue laying the adjacent tiles using the same process until completing the surface to be covered.

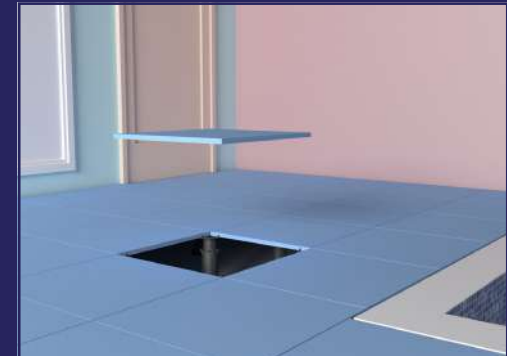

## 8° Registrable surface

Finally, we obtain a completely registrable surface which allows us access to lower installations such as electrical wiring, sump, piping, etc.

# How many Pedestals do you need?

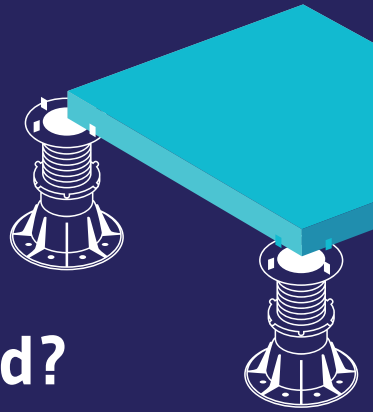

FLOORING	PEDESTALS
40 x 40	→ 6,7 units/m <sup>2</sup>
40 x 60	→ 4,2 units/m <sup>2</sup>
40 x 90	→ 3 units/m <sup>2</sup>
50 x 50	→ 4,2 units/m <sup>2</sup>
60 x 60	→ 3,3 units/m <sup>2</sup>
90 x 90	→ 3,6 unid./m <sup>2</sup>

- Approximate quantity by the manufacturer  
 - Optional central Pedestal is not include

### Example:

Surface: 100 m<sup>2</sup>

Tile: 50x50 = 4,2 units/m<sup>2</sup>

### PEDESTALS:

100 x 4,2 = **420 units.**

# PIECES

## 1 Pad

Pad made of an elastomer material which offers noise and slipping resistance.

## 2 Head

Head may of polypropylene with charges. Provided with 4 mm spacers. The thread offers resistance over 1,500 kg.

## 3 Locknut

The locknut blocks the Pedestal to avoid being loosened over time.

## 4 Floating nut

The floating nut allows the adjustable Pedestal to be lifted or lowered without raising the tile. The nut is subject to pressure avoiding the Pedestal from being disassembled.

## 5 Bushing

Supplement to raise the adjustable Pedestal to 90mm. Can be coupled and lifted until the height wanted.

## 6 Base

Adjustable Pedestal. Water outlets to prevent from water accumulation in it. The holes on the base facilitate its fixing to the floor with polyurethane if necessary.

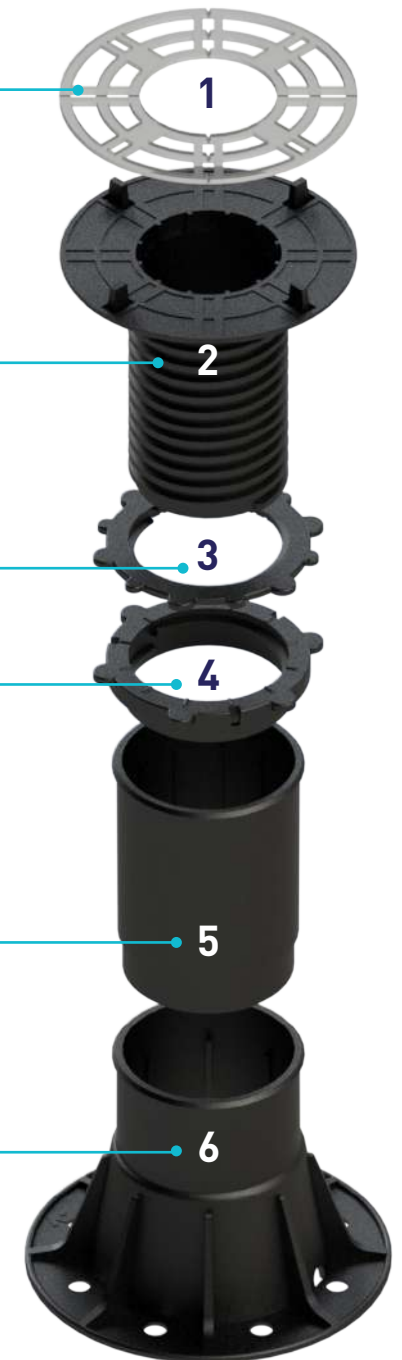



# CALCULATOR Peygran



CALCULATE  
NOW

Automatically calculate the pedestals you need.

With our software Peygran Calculator you can calculate the number and type of raised floor supports you will need for your project. You can introduce the plans or draw the surface of the building to get the calculation of the raised floor pedestals depending on the type and ceramic format, wooden decking, sinkhole and currents of the surface to be treated.

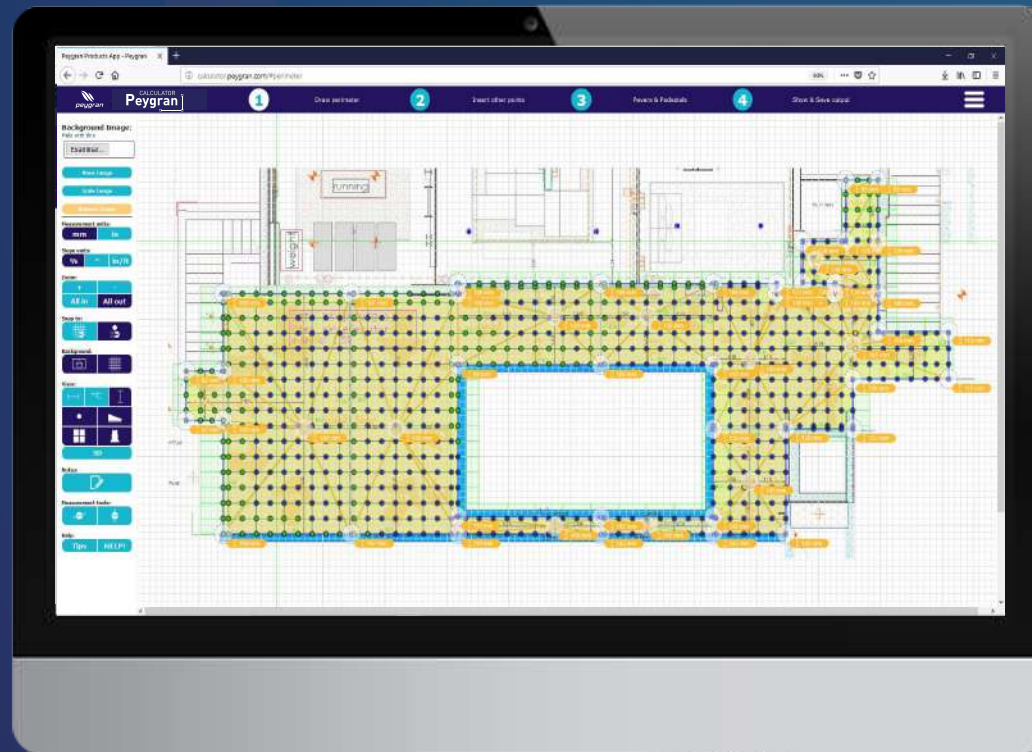

www.peygran.com

3. Plot detail:

Model	Description	Quantity
x	-	-
+	-	-
●	Fixed plot 10 Height of 10	0
●	Fixed plot 15 Height of 15	0
●	SP Height from 37 - 50	0
●	SP0 Height from 50 - 75	0
●	SP1 Height from 80 - 130	0
●	SP2 Height from 130 - 220	0
●	SP3 Height from 220 - 310	0
●	SP4 Height from 310 - 400	0
●	SP5 Height from 400 - 490	0
●	SP6 Height from 490 - 580	0

This color refers to Image 1.  
Approximate number of plots.

2  
www.peygran.com

1 Create perimeter

2 Water spring

3 Tile type

4 Final result



## 1 CREATE PERIMETER

The first step is to designate the perimeter that you are going to raise with pedestals. For that purpose, you can upload your own plane to the software and use it as a template or draw it directly.



## 2 WATER SPRING

The next step is to place the drains that the installation has. The height of each point of the perimeter is fundamental to calculate the slope that is towards each sink.



## 3 TILE TYPE

Once the entire area to be installed is limited, we move to the choice of the pavement. Enter the dimensions of the tile to install. We can choose between ceramic tile or wooden flooring.



## 4 FINAL RESULT

The software automatically calculates the amount of pedestals you need for your installation and the model in each section.

The calculation can be downloaded in pdf with all necessary components disaggregated. You can save and load your projects to consult, make modifications or request a quote directly.

Image 2: Use of slope correctors.

Table B: Slope corrector details		
#	Description	Quantity#**
○	No slope correction needed.	-
●	Regulador inclinación Type: Regulador inclinación	304
●	Regulador inclinación Type: Regulador inclinación Link2	378



# Fixed Pedestals

## 10 and 15 mm Fixed Pedestals

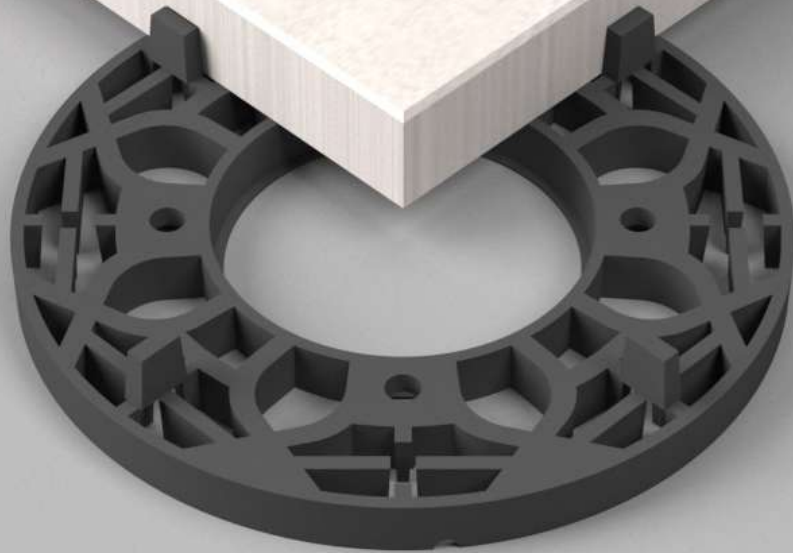

Non-adjustable Pedestals are 10 and 15mm. Can be fitted to each other to reach the height wanted.

Compatible with pads and adjustable Pedestals. Can be fitted to the head. Base only available without inclination. Resistance over 6,000 Kg.

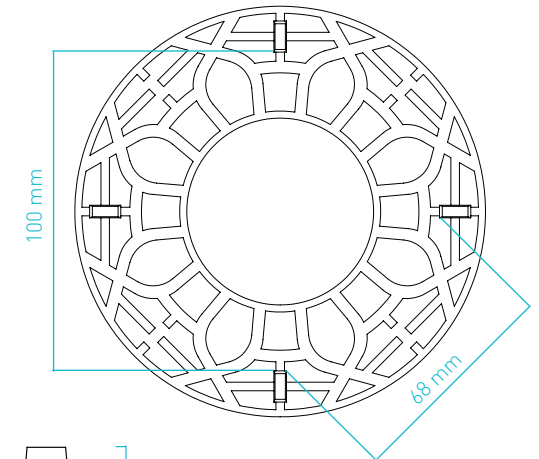

### 10 Pedestal

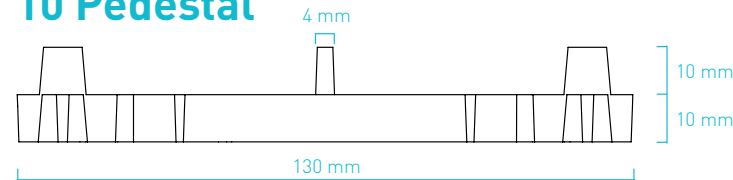

### 15 Pedestal

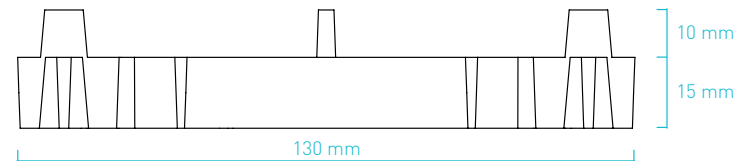

Ref.	Description	mm	Units (/Box)	Box (cm)	Weight (kg)
0200206	10 mm fixed Pedestal	10	444	59x39x41	23,98
0200207	15 mm fixed Pedestal	15	300	59x39x41	25,20

For orders, it is necessary to ask for and fill in the "Pedestals pick-up sheet"



# Ajustable Pedestal **SP** y **SP0**

Adjustable Pedestals.

Compatible with the pads to isolate and chock, with the fixed Pedestals to supplement if needed and with the locknut to block the Pedestal.

The base is available flat and 1 and 2% inclination.

Resistance over 1,500kg

Top diameter	<b>130,00 mm</b>
Bottom diameter	<b>159,50 mm</b>

**SP**

37 - 50 mm

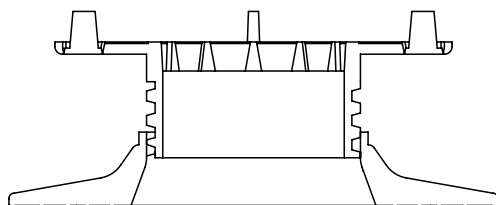

**SP0**

50 - 75 mm

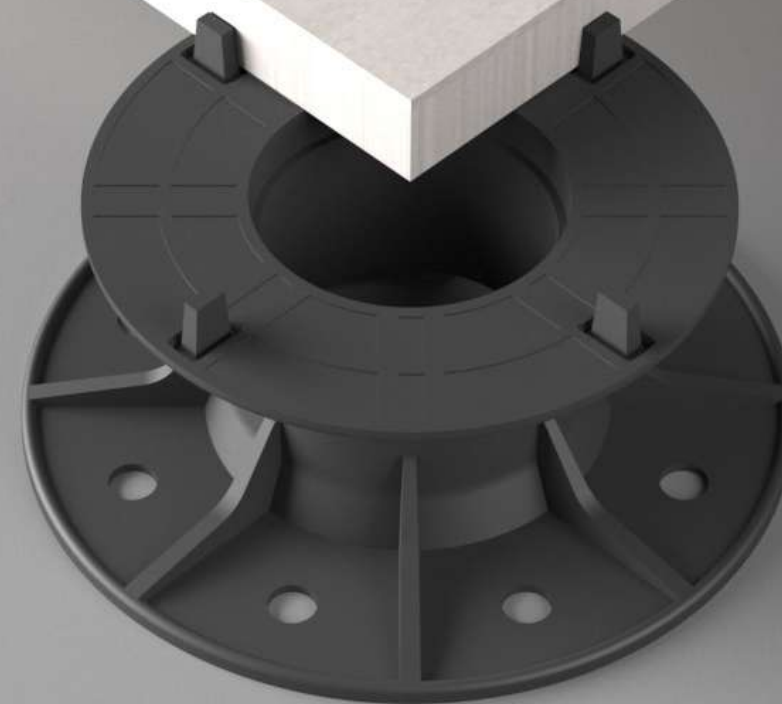
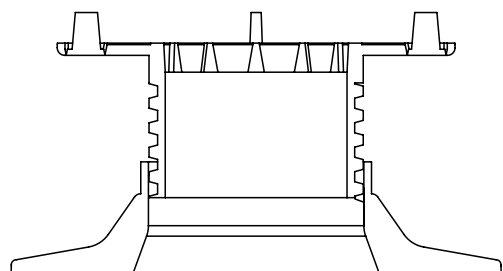

Ref.	Description	mm	Units (/Box)	Box (cm)	Weight (kg)
<b>SP</b>	Pedestal for floating floors	<b>37 - 50</b>	96	59x39x41	12,52
<b>SP0</b>	Pedestal for floating floors	<b>50 - 75</b>	72	59x39x41	11,38

For orders, it is necessary to ask for and fill in the "Pedestals pick-up sheet"



# Adjustable Pedestal SP1 and SP2

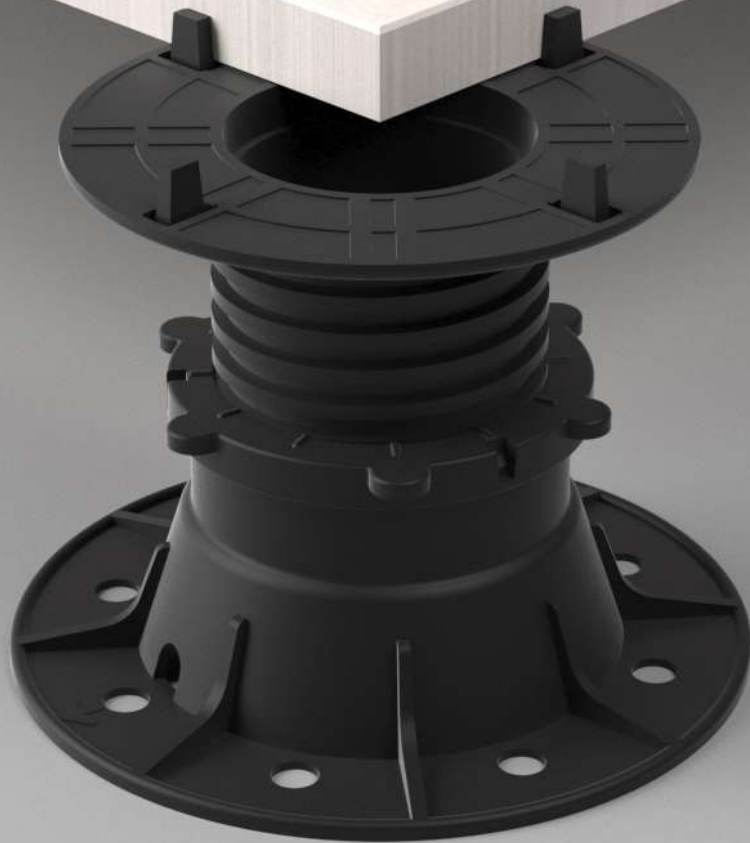

Adjustable Pedestals.

Compatible with the pads to isolate and chock, with the fixed Pedestals to supplement if needed and with the locknut to block the Pedestal.

The base is available flat and 1 and 2% inclination.

Resistance over 1,500kg

Top diameter	<b>130,00 mm</b>
Bottom diameter	<b>159,50 mm</b>

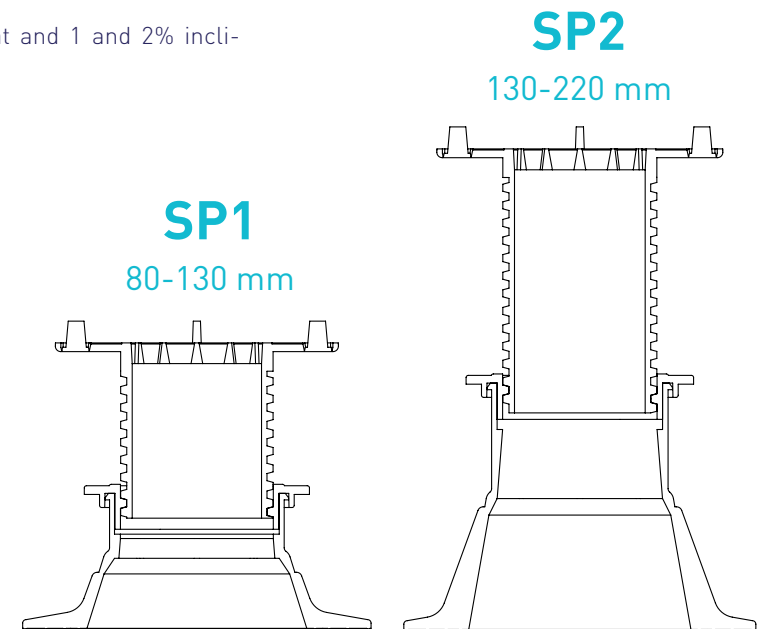

Ref.	Description	mm	Units (/Box)	Box (cm)	Weight (kg)
SP1	Pedestal for floating floors	80 - 130	48	59x39x41	11,30
SP2	Pedestal for floating floors	130 - 220	40	59x39x41	12,56

For orders, it is necessary to ask for and fill in the "Pedestals pick-up sheet"





# Adjustable Pedestal SP3 - SP4 - SP5 - SP6

Adjustable Pedestals. Compatible with the pads to isolate and chock, with the fixed Pedestals to supplement if needed and with the locknut to block the Pedestal.

Top diameter **130,00 mm**  
Bottom diameter **159,50 mm**

The base is available flat and 1 and 2% inclination.

Resistance over 1,500kg

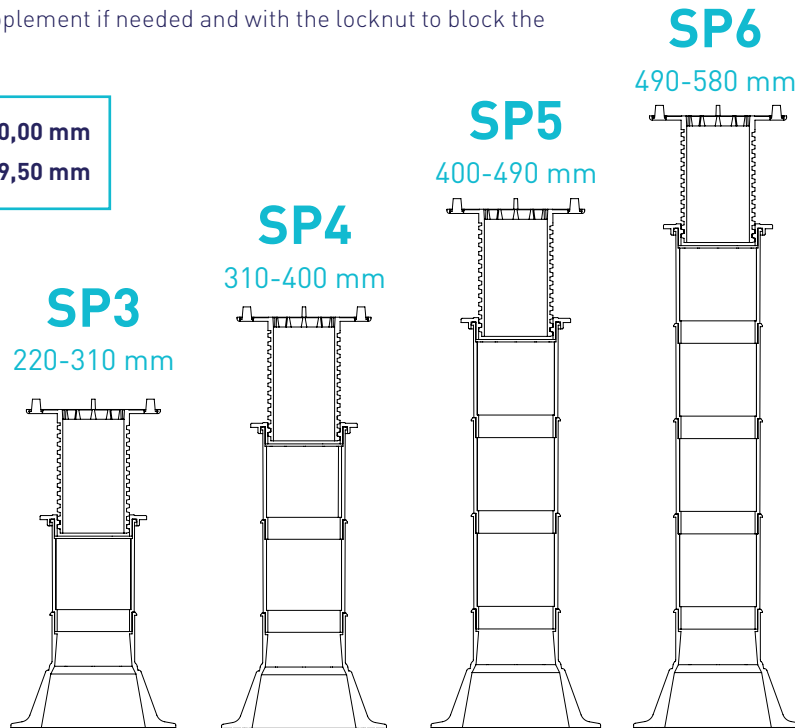

Ref.	Description	mm	Units (/Box)	Box (cm)	Weight (kg)
SP3	Pedestal for floating floors	220 - 310	20	59x39x41	7,43
SP4	Pedestal for floating floors	310 - 400	15	59x39x41	5,62
SP5	Pedestal for floating floors	400 - 490	12	59x39x41	6,54
SP6	Pedestal for floating floors	490 - 580	12	59x39x41	7,46

For orders, it is necessary to ask for and fill in the "Pedestals pick-up sheet"





# Aluminium Joist

Peygran Pedestals for outside spaces with head for Aluminium Joist are the ideal solution for projects in which wood or wpc floating platforms are installed.

They are an excellent alternative to other traditional methods allowing for greater versatility when making the joist frame, thanks to the rotating clip of the joist head.

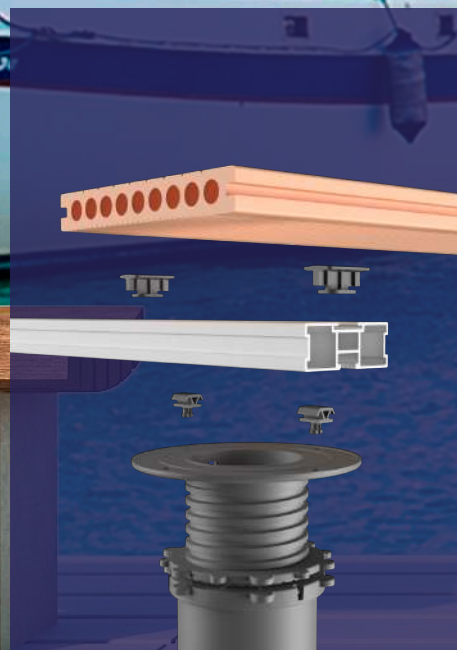

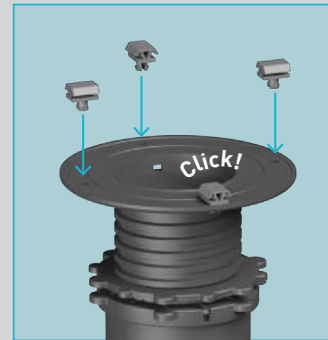

New clip for joists. They are inserted into flat heads easily to anchor the Pedestal to the Aluminium Joist.

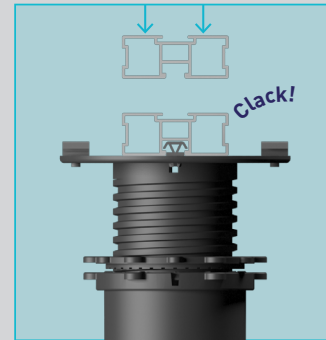

Simply press the joist on the clip and it will be safely anchored to it.

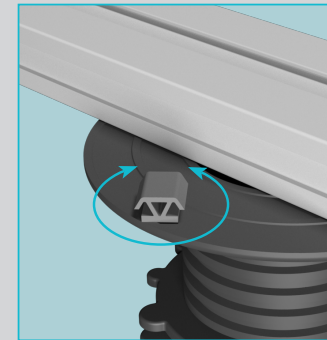

The clip for joists can turn 360° to fit the joist to the degrees wanted in order to make a solid aluminium frame.

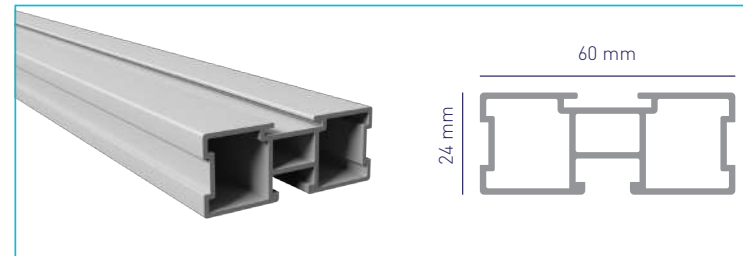
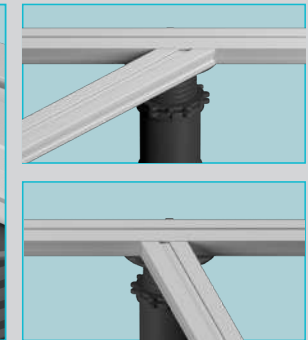

## Aluminium Joist

Aluminium Joists make assembly of raised platforms easy.

Ref.	Description
0200166	Aluminium Joist



## Joist Clip

Fixes the laminated floor to the Aluminium Joist safely and effectively without the need to screw all the pieces.

Ref.	Description	Units
0200168	Joist Clip	100



## Head Without Flanges

Head used as a support of elements without gaps or joints between pieces. Product upon request. Consult availability.

Ref.	Description
0200163	Head Without Flanges



# Accessories / Aluminium Joist

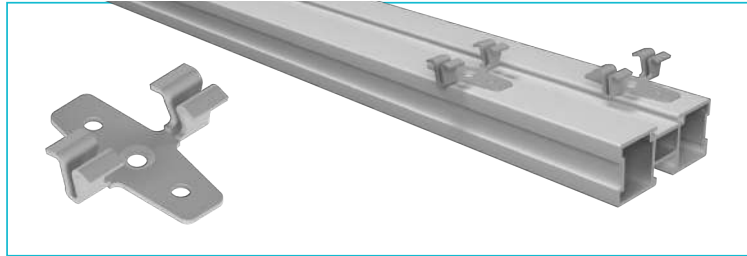

## Steel Decking Anchor

Fixes the laminated floor permanently to the joist. It is necessary to screw it. Board between slats of 6 mm

Ref.	Description	Units
0500005	Steel Decking Anchor	1

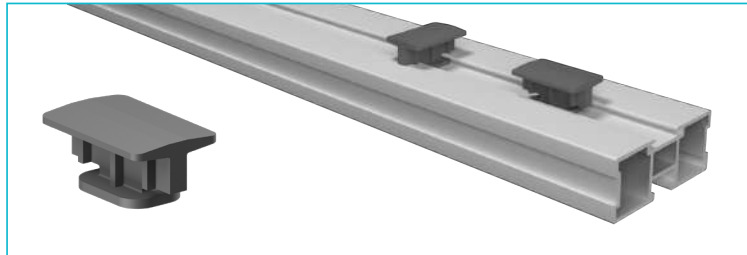

## Fast Decking Anchor

Fixes the laminated floor to the aluminium joist safely and effectively without the need to screw all the pieces. Joint between slats of 4 mm.

Ref.	Description	Units
0200164	Fast Decking Anchor	100

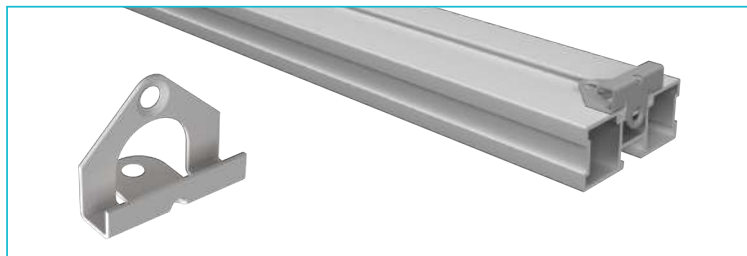

## Start Decking Anchor

It works as fastening of the slats placed in the perimeter of the installation. It is necessary to screw it.

Ref.	Description	Units
0500006	Start Decking Anchor	1

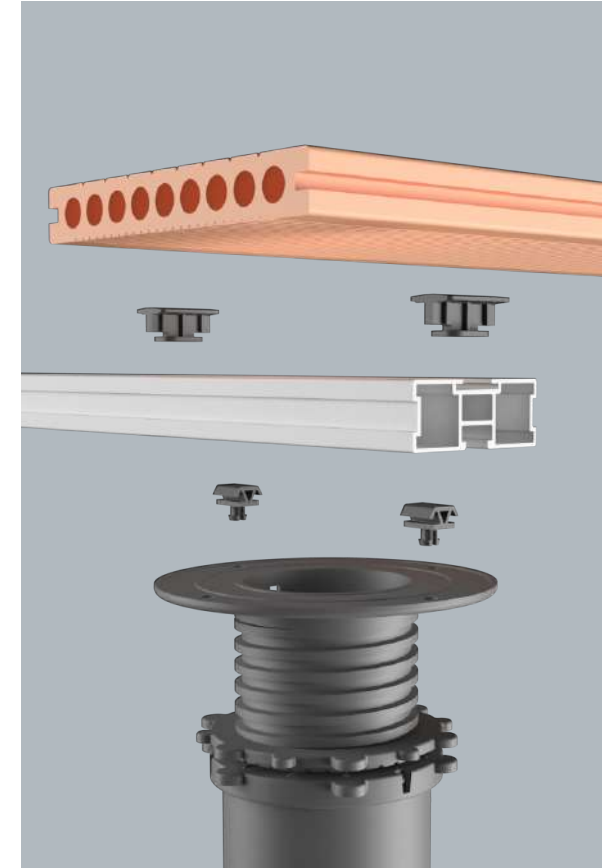



# Aluminium joist - HOW TO USE



## 1° Set the surface

Set the surface and place the Pedestals at the right distance according to the lay out wanted, characteristics and dimensions of the slats and planking (Maximum recommended distance; between joists 30 cm, between pedestals 40 cm). It is important that the heading joints coincide with the joists.



## 2° Assemble the frame and level

Place the joists and assemble the frame according to the dimensions and weight of the platform. Next, level the joists.

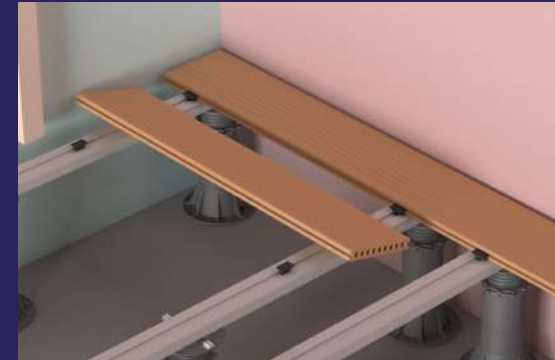

## 3° Install the first slats

Start by laying the first row of the platform slats. Start by one of the corners of the area to be planked. The heading joints must always coincide with the joists.



## 4° Fix the slats to the joist by means of

Placing of fixings in slots in joists and slats.



## 5° Continue with the adjacent slats

Continue the assembly according to the previous steps.



## 6° Finish installation

Complete and safe finish of Peygran system.



## Tile Joist Spacer

They are placed in the Aluminum Joist and have the function of separating the pieces of the floor that is installed on the aluminum joist structure.

Separate efficiently with a joint between tiles of 4 mm. It can separate into I, T and X.

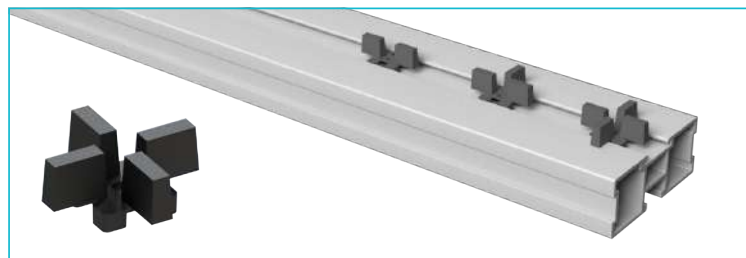
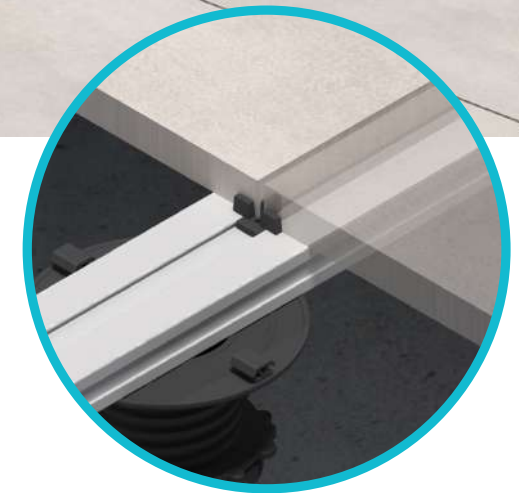
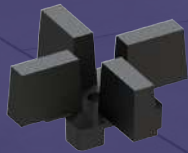

### Tile Joist Spacer

Placed in the aluminium joist. Their function is to separate the floor effectively. Joint between tiles of 4 mm.

Ref.	Description	Units
0200165	Tile Joist Spacer	100



# Wood Joist Head

Wooden floorboards are a very aesthetic solution for our raised floors, for which we have our head with for wooden flooring.

Specially for wooden joists projects. The finish we get with this material creates a warmer environment.

The head has a lateral support to be able to fix the joists.

Is compatible with all sp models.

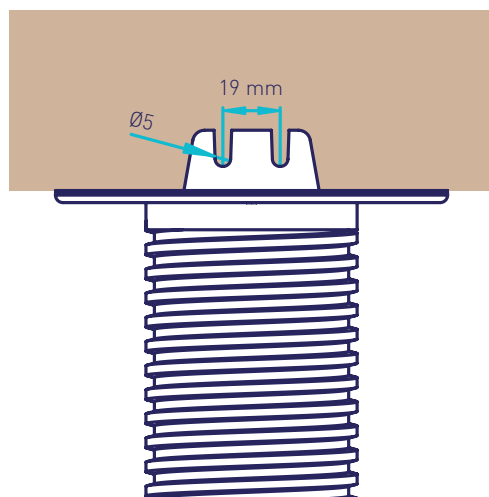
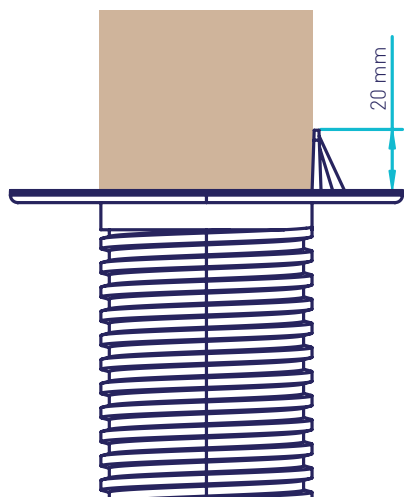
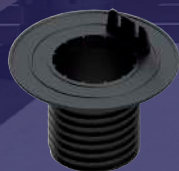

## Wood Joist Head

**Ref.**                      **Description**

0200162                      Wood Joist Head



# Complements



## Head Without Flanges

Head used as a support of elements without gaps or joints between pieces. Product upon request. Consult availability.

Ref.	Description
0200163	Head without flanges

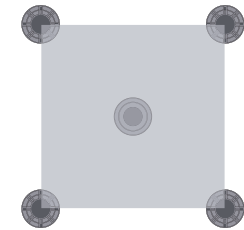
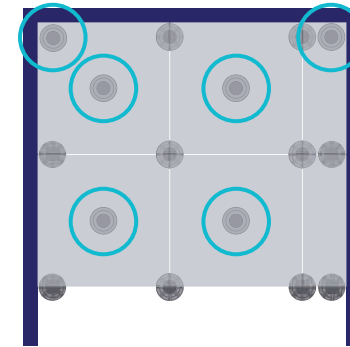

**Central Pedestal**  
recommended for  
tiles from **60x60cm**



## Head Joint 2mm/3mm

We offer two supplementary models for heads without flanges for finishes with different joints.

Ref.	Description
0200169	Head Joint 2 mm
0200170	Head Joint 3 mm

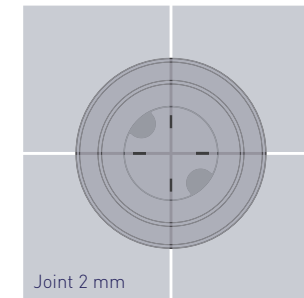

Joint 2 mm

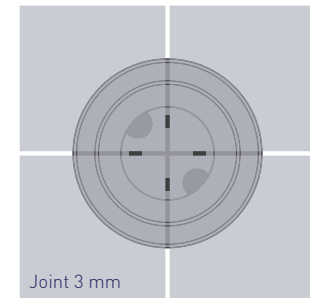

Joint 3 mm

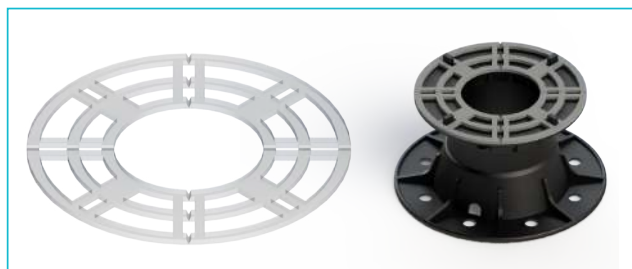

## Pedestal Pad

Pads offer acoustic insulation and slip resistance. Can be cut into pieces through the existing pre-cuts to chock. 2.5 mm thick, made of elastomer material. It has 2 flanges that prevent dislocation in needs without flanges.

Ref.	Description
0200208	Pedestal Pad





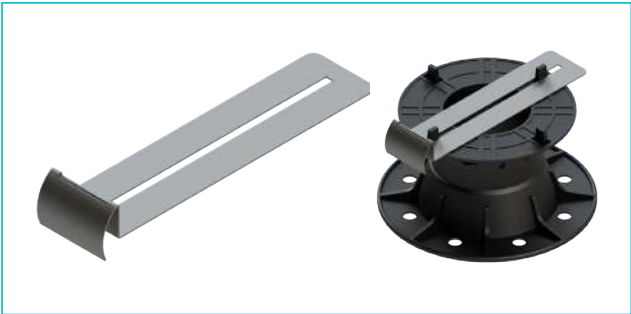

### Perimeter Dilator

Works as an expansion joint in the entire perimeter of the installation of raised floors.

Ref.	Description
0200306	Perimeter Dilator

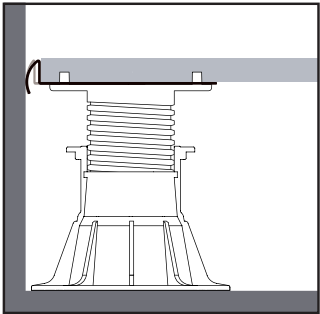

### Vertical Closing

Allows us to complete the finish of raised floors that have no walls around the entire perimeter. It is also used for producing steps at different heights within a composition.

One closing is hooked to the Pedestal at the bottom and the other one at the top. For corners, put 2 at the head and 2 at the base perpendicularly.

With the base, the Pedestal does not loose strength or tilts due to the bottom sheet.

Ref.	Description
0200307	Vertical Closing

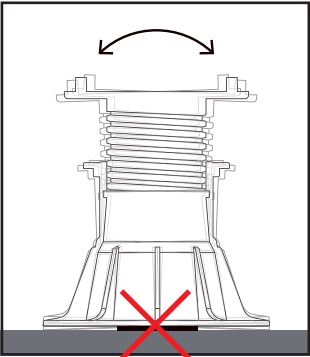
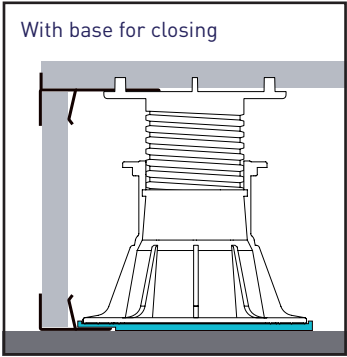

The bottom sheet fits perfectly to the base for vertical closing. In this way, the entire base of the Pedestal is supported correctly and has no reduction in resistance.

If the Pedestal tilts, it loses the base support and therefore, it loses resistance and wears.



# Slope Regulator

These wedge-shaped discs allow us to adjust inclination at the base of the Pedestal easily and quickly.

Several regulators can be coupled to obtain the currents wanted and turn them individually to orientate inclination and percentage of unevenness.

With each regulator we can obtain maximum unevenness of 2,5%.

With each regulator the Pedestal is lifted by 3 mm.



Ref.	Description	Slope
0200161	Slope Regulator	2,5 %

## Positions

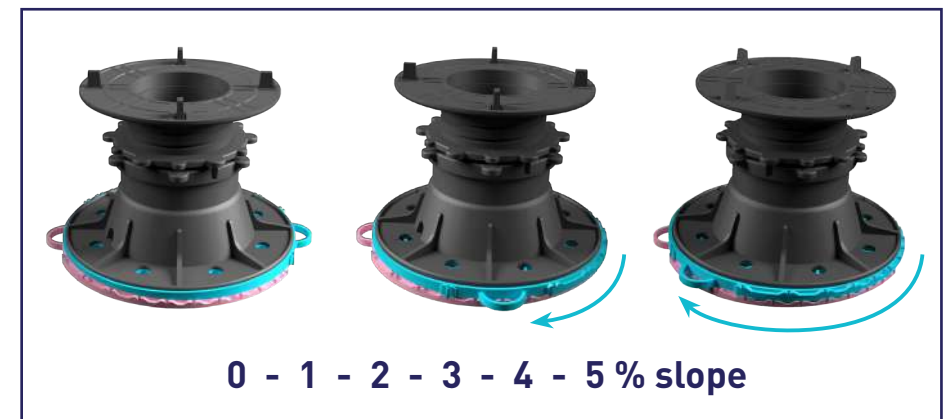
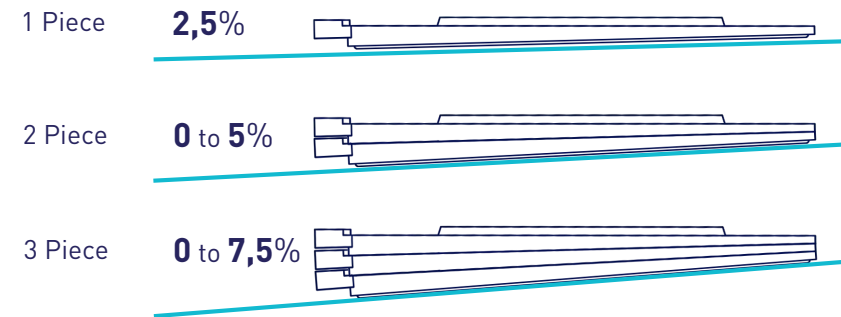
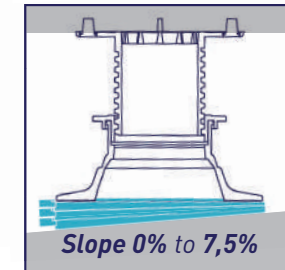
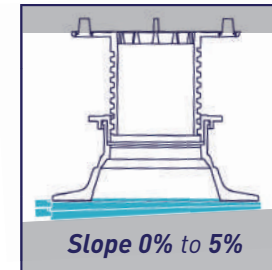
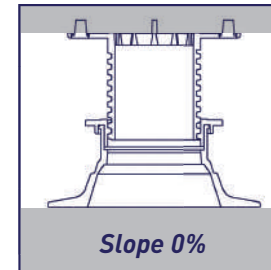

When several pieces are combined we can get all the inclination percentages lower than the maximum slope. We use several regulators to find the exact inclination. Each tab that we rotate to the regulator we add 0,25° of inclination



### Locknut

The locknut blocks the Pedestal to avoid being loosen over time due to vibrations or adverse weather conditions.



- 1° Insert the locknut in the Pedestal head, at the top of the thread.
- 2° When the floor is levelled and the Pedestal has its final position, take it to the bottom to block the Pedestal.



Ref.	Description
0200146	Locknut



### Wrench for locknuts

Wrench for tightening the locknut against the Pedestal nut. Made of the same material as the Pedestals.

Ref.	Description
hplot	Wrench for tightening the locknut

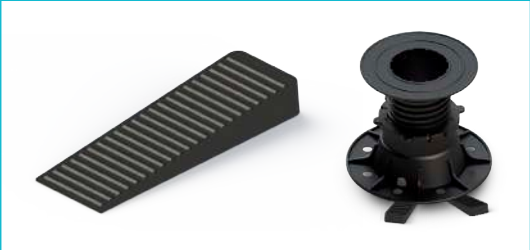

### Wedge for technical floors

Wedges for chocking technical floors. Shoulders on the wedge help fixing to the support. Made of polypropylene. Measures: 5.5mm high and 45,75mm long. Point 0.3 mm.

Ref.	Description
0200059	Wedge for technical floor

Units	Bags (per box)	Box (cm)	Weight (kg)
1.000	22	27x18x16	22



### Thickened hook

Allows us to remove the floor efficiently and without effort. It avoids damaging the pieces. Opening 400-600mm. 30kg maximum.

Ref.	Description
0200172	Thickened hook





# SUMMARY TABLE OF PEDESTALS

## Compatibilities



REF.	Plot10	Plot15	SP	SP0	SP1	SP2	SP3	SP4	SP5	SP6
<b>Height (mm)</b>	<b>10</b>	<b>15</b>	<b>37 - 50</b>	<b>50 - 75</b>	<b>80 - 130</b>	<b>130 - 220</b>	<b>220 - 310</b>	<b>310 - 400</b>	<b>400 - 490</b>	<b>490 - 580</b>
Weight (gr.)	54	84	135	160	230	315	390	470	550	630
Resistance	6.000	6.000	1.300	1.300	1.400	1.500	1.500	1.500	1.500	1.500
Floating Nut	-	-	-	-	✓	✓	✓	✓	✓	✓
Inclined Base	-	-	0% - 1% - 2%	0% - 1% - 2%	0% - 1% - 2%	0% - 1% - 2%	0% - 1% - 2%	0% - 1% - 2%	0% - 1% - 2%	0% - 1% - 2%
Slope Tegulator	✓	✓	✓	✓	✓	✓	✓	✓	✓	✓
Locknut	-	-	-	-	✓	✓	✓	✓	✓	✓
Pad	✓	✓	✓	✓	✓	✓	✓	✓	✓	✓
Wood Joist Head	-	-	✓	✓	✓	✓	✓	✓	✓	✓
Aluminium Joist Head	-	-	✓	✓	✓	✓	✓	✓	✓	✓
Head Without Flanges	-	-	✓	✓	✓	✓	✓	✓	✓	✓
Head Joint 2/3 mm	✓	✓	✓	✓	✓	✓	✓	✓	✓	✓
Perimeter Dilator	✓	✓	✓	✓	✓	✓	✓	✓	✓	✓
Vertical Closing	-	-	✓	✓	✓	✓	✓	✓	✓	✓



0 a 2 % slope

1 Inclined Base



1,5 % slope

2 Slope Regulator



3 Locknut

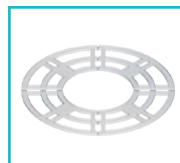

4 Pad



5 Wood Joist Head



6 Aluminium Joist Head



7 Head Without Flanges



8 Head Joint 2/3 mm



9 Perimeter Dilator

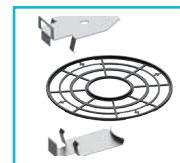

10 Vertical Closing

# DISPLAY

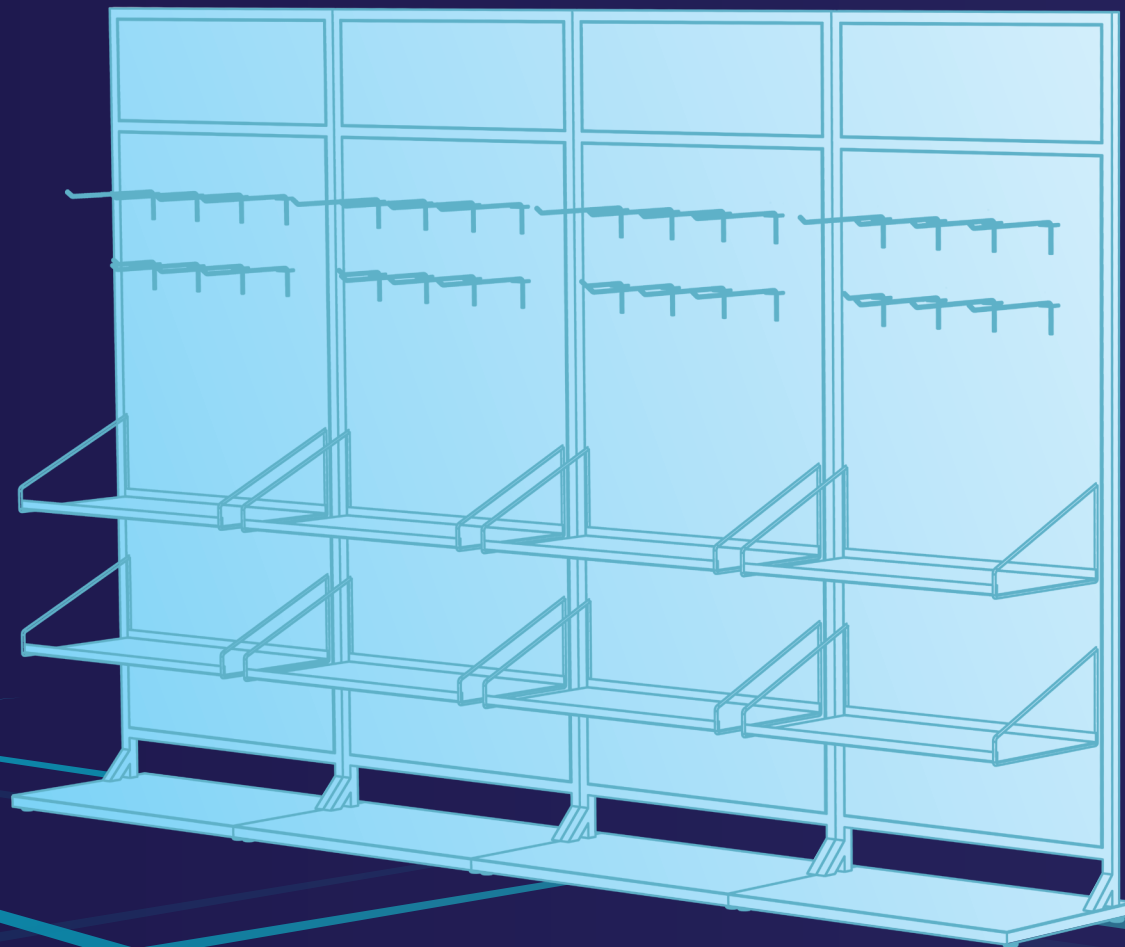

# Peygran Displays

**Get the new Displays.** It is a new design of exhibitor, much more attractive, bigger and that ostensibly improves the communication of the product and its characteristics or attributes, giving greater visibility at the points of sale.

This increases the perceived value of the product and allows the final customer to identify Peygran products more efficiently.

**+ info:**  
[info@peygran.com](mailto:info@peygran.com)



**CARDBOARD Display**  
 (65x162x40cm)



**SIMPLE Display** (200x100x40cm)



**PLUS CUSTOMIZED Display** (200x200x40cm).







# GENERAL SALES CONDITIONS



## ORDERS

Order should be placed and sent by email to [sergiosegui@peygran.com](mailto:sergiosegui@peygran.com) or by phone. Orders will not be considered as definitive until buyer and seller have expressly accepted in writing.

The range of raised floor products, due to hygienic and safety reasons, can not be returned. It will be necessary to fill out the requested pedestal sheet.



## CUSTOMER SERVICE

Business hours are from 9:00 to 13:00 and from 15:00 to 17:00 from Monday to Friday.



## TRANSPORT

- Ex-works conditions.



## PREPARATION AND DELIVERY RATES

Anyway, delivery dates indicated to customers are purely informative and delays that may occur shall not entitle customers to compensation.



## SHIPPING AND CLAIMS

When receiving the goods, consignees should check that packages and quantities received coincide with our delivery note and their orders. Consignees should also check that goods are appropriately packaged and without damages. In the case of any defect detected when receiving the goods, please indicate this on the carrier's sheet.

Claims and returns will not be accepted after 5 days from the date of receipt. In case of any claim, you should send an email to [sergiosegui@peygran.com](mailto:sergiosegui@peygran.com) detailing the reason for the claim.



## RESERVATION OF TITLE

Peygran reserves the title of the goods delivered, delivered at the customer's facilities or at any other place, until the customer has fully paid for that sale. When fully paid, the title will be transferred to the customer.



## METHOD OF PAYMENT

- First order: advanced payment via bank transfer.  
Rest of orders: Transfer or direct debit, after credit is accepted by the insurance company.
- The payment deadline for invoiced goods will be 60 days.  
For direct debit, please fill in and sign the SEPA direct debit order.



## PRICES

In the event of changes to prices, the current prices at the time the order is accepted by Peygran will be applied. Prices of our list are net prices. VAT, taxes or fees of any other kind that may apply to the sale are not included.



## SPECIAL CONDITIONS – CUSTOMERS

Purchase conditions set by customers on their orders that are contradictory with regard to these sales conditions shall be valid only if expressly accepted in writing by Peygran.



## JURISDICTION

In case of disputes, the customer submits to the Courts of Ibi (Alicante), Spain.



Development and manufacture of parts <  
and special components

Specialized in civil engineering and construction, <  
both in plastic and metal

Technical solutions <

Own brand <

Technical advice <



C/ Castellón de la Plana, 31  
03440 **Ibi** ( Alicante ) SPAIN



(+34) **966 550 514**  
(+34) 965 554 573



**info@peygran.com**



**www.peygran.com**